

# IALA Technical Clarifications

on

## ITU Recommendation

**ITU-R M.1371-1**

**Edition 1.4**

**December 2003**



## TABLE OF CONTENTS

<b>1</b>	<b>INTRODUCTION</b>	<b>5</b>
<b>2</b>	<b>TECHNICAL CLARIFICATIONS OF ITU-R M.1371-1</b>	<b>8</b>
2.1	A1; § 4.2.1 Reporting Rate	8
2.2	A2; § 1 Structure of this annex	10
2.3	A2; § 2.3 Transceiver characteristics	12
2.4	A2; §3.1.1.3 Synchronized to base station (Direct or Indirect)	12
2.5	A2; §3.1.3.3 Synchronization - Transmitting stations (see Figure 1)	13
2.6	A2; § 3.1.3.3.1 Base station operation	14
2.7	A2; §3.1.3.3.2 Mobile station operation as a semaphore	14
2.8	A2; § 3.1.3.4 Synchronization - Receiving stations (see Figure 2)	15
2.9	A2; § 3.1.3.4.1 UTC available	15
2.10	A2; § 3.1.3.4.2 Own transmission slot number equal to the received semaphore slot number	16
2.11	A2; § 3.1.3.4.3 Other synchronization sources	16
2.12	A2; § 3.2.2.1 Bit stuffing	19
2.13	A2; § 3.2.2.8.1 Bit stuffing	19
2.14	A2; §3.3.1.2 Candidate slots	20
2.15	A2; §3.3.2 Modes of operation	24
2.16	A2; §3.3.2.1 Autonomous and continuous	24
2.17	A2; § 3.3.2.2 Assigned	24
2.18	A2; § 3.3.4.4 Self-Organizing TDMA - SOTDMA	25
2.19	A2; § 3.3.4.4.2 SOTDMA parameters	26
2.20	A2; § 3.3.5.1.1 Monitor VHF data link (VDL)	27
2.21	A2; § 3.3.5.1.2 Network entry after one minute	28
2.22	A2; § 3.3.5.2 Network entry phase	28
2.23	A2; § 3.3.5.2.2 Select Nominal Transmission Slot (NTS)	29
2.24	A2; § 3.3.5.3 First frame phase	30
2.25	A2; § 3.3.5.3.1 Normal operation after one frame	30
2.26	§ 3.3.5.3.2 Set offset to zero	31

2.27	A2; § 3.3.5.3.4 Add offset to this transmission	31
2.28	A2; § 3.3.5.4.3 Slot Time -Out is zero	31
2.29	A2; § 3.3.6 Assigned operation	32
2.30	A2; § 3.3.6.2.2 Operating in the assigned mode	32
2.31	A2; § 3.3.6.2.3 Returning to autonomous and continuous mode	33
2.32	A2; § 3.3.7 Message structure	33
2.33	A2; §3.3.7.2.2 SOTDMA Communication State	34
2.34	A2; § 3.3.7.2.3 SOTDMA Communication State Sub Messages	36
2.35	A2; §3.3.7.3.2 ITDMA Communication State	36
2.36	A2; § 3.3.7.4.2 RATDMA message structure	37
2.37	A2; §3.3.7.5 FATDMA message structure	37
2.38	A2; § 3.3.8.1 Message summery	38
2.39	A2; § 3.3.8.2.1 Message 1, 2, 3: position reports	41
2.40	A2; §3.3.8.2.2 Message 4: Base station report Message 11: UTC and date response	43
2.41	A2; § 3.3.8.2.3 Message 5: Ship Static and Voyage related data	44
2.42	A2; § 3.3.8.2.3.3 Reference Point for reported position and Dimensions of Ship	46
2.43	A2; § 3.3.8.2.7 Message 9: Standard SAR Aircraft Position Report	49
2.44	A2; § 3.3.8.2.11 Message 15 Interrogation	54
2.45	A2; § 3.3.8.2.12 Message 16: Assigned Mode Command	55
2.46	A2; 3.3.8.2.14 Message 18: Standard Class B Equipment Position Report	58
2.47	A2; § 3.3.8.2.15 Message 19: Extended Class B Equipment Position Report	60
2.48	A2; §3.3.8.2.16 Message 20: Data Link Management Message	61
2.49	A2; § 3.3.8.2.17 Message 21: Ai ds to Navigation Report	63
2.50	A2; § 4.1.1 Operating frequency channels	68
2.51	A2; §4.1.2 Normal default mode of dual channel operation	69
2.52	A2; § 4.1.5 Transitional mode operations near regional boundaries	70
2.53	A2; § 4.1.6 Channel management by manual input	72
2.54	A2; § 4.1.8 Priority of channel management commands	72
2.55	A2; § 4.3.2 Assigned Reporting Rates	75
2.56	A2; §4.4.1 Intentional Slot Reuse by the own station	75

<b><i>XF</i></b>		<b>76</b>
<b>2.57</b>	<b>A2; § 4.4.2 Use of Assignment for Congestion Resolution</b>	<b>79</b>
<b>2.58</b>	<b>A2; § 4.5 Base Station Operation</b>	<b>80</b>
<b>2.59</b>	<b>A2; § 4.6 Repeater Operation</b>	<b>80</b>
<b>2.60</b>	<b>A2; § 4.6.1.2 Base station/repeater station use of Repeat Indicator</b>	<b>81</b>
<b>2.61</b>	<b>A2; § 4.6.3.3 Synchronisation and Slot selection</b>	<b>81</b>
<b>2.62</b>	<b>A2; §5.2.1 Conversion to transmission packets</b>	<b>81</b>
<b>2.63</b>	<b>A2; § 5.3.1 Addressed message</b>	<b>82</b>
<b>2.64</b>	<b>A3; § 1 General</b>	<b>85</b>
<b>2.65</b>	<b>A3; § 2 Scheduling</b>	<b>86</b>
<b>2.66</b>	<b>A3; § 3 Polling</b>	<b>86</b>
<b>2.67</b>	<b>A3; § 4 Regional channel designation</b>	<b>87</b>
<b>2.68</b>	<b>A3, § 5 Regional area designation</b>	<b>87</b>
<b>2.69</b>	<b>A5; § 3.1 International Function Message 0: Text telegram using 6-bit ASCII</b>	<b>89</b>
<b>3</b>	<b>MAPPING OF SECTIONS OF M.1371-1 TO DIFFERENT KIND OF AIS STATIONS</b>	<b>90</b>
<b>3.1</b>	<b>General</b>	<b>90</b>
<b>3.2</b>	<b>Sections or paragraphs</b>	<b>90</b>
<b>3.3</b>	<b>Section/paragraphs describing Messages</b>	<b>91</b>

# Technical Clarifications of Recommendation ITU-R M.1371-1 (Edition 1.4)

## 1 Introduction

- 1.1 The purpose of AIS is to improve the maritime safety and efficiency of navigation, safety of life at sea and the protection of the marine environment.
- 1.2 It has long been realized that an automatic reporting device fitted to a ship would have the potential to increase significantly the safety of navigation and would allow the improved control and monitoring of the maritime environment. Taking up this challenge, the International Maritime Organization (IMO) together with the International Telecommunications Union (ITU) and the International Electrotechnical Commission (IEC) developed a new navigation system called the Automatic Identification System (AIS).
- 1.3 Recommendation ITU-R M.1371-1 is the document that describes the technical characteristics for a Universal Shipborne Automatic Identification System using Time Division Multiple Access in the VHF Maritime Mobile Band. As with any technical document some concepts are subject to interpretation. This document presents a series of clarifications for some of these concepts as agreed by the IALA AIS Committee.
- 1.4 Figure 1 (attached) illustrates the inter-relationship of this document to IMO SOLAS Chapter V; the IMO recommendation on Performance Standards for a Universal Shipborne Automatic Identification System (AIS), (MSC.74(69)); the IMO Guidelines for the Onboard Operational Use of the Shipborne AIS (A.917(22)); the ITU Recommendation on the Technical Characteristics for a Universal Shipborne Automatic Identification System (AIS) using Time Division Multiple Access in the Maritime Mobile Band (ITU-R M.1371-1); and the IEC Standard 61993-Part 2: Universal Shipborne Automatic Identification System (AIS) Operational Performance Requirements, Methods of testing and required test results; the IALA Guidelines on Automatic Identification Systems (AIS).
- 1.5 As shown in Figure 1, each of the referenced documents in paragraph 1.4 including this document has a specific focus in relation to an overall AIS as follows.

This document, "Recommendation on Technical Clarification of ITU-1371-1", deals specifically with the VHF Data Link (VDL) of an AIS. It acknowledges the fact that some of the specific technical paragraphs in ITU-R M.1371-1 might

require interpretations as to their precise, intended meaning. Consequently, this document presents a set of unifying recommendations that will, hopefully, result in a standardized application of these paragraphs by potential manufacturers, system integrators as well as users of the systems. Adherence to these recommendations will ensure the viability of the VDL and the interoperability among AIS units obtained from different sources.

1.6 However, this document, whose specific focus is shown by the outline in Figure 1, also covers some other specific, technical details of various possible AIS station or device configurations that are only mentioned in general terms in ITU-R M.1371. These specific details are presented in section 2 of this Recommendation in the tables entitled "Mapping of M.1371-1 to the functional requirements of different kinds of AIS devices". The AIS devices/stations covered by this mapping process are:

- class A shipborne mobile stations,
- class B shipborne mobile stations,
- SAR aircraft mobile stations,
- Aids to Navigation stations,
- Base Stations,
- Simplex Repeater Stations, and
- Duplex Repeater Stations.

Mapping the overall requirements of ITU-R 1371 to these specifically identified AIS devices will enable manufacturers, system integrators and users alike to obtain a comprehensive understanding of their similarities and important differences and limitations thus ensuring their most effective and applicable use.

1.7 The scope of the other documents, referred to in para. 1.4 can be derived from the specific borderlines as shown in the Figure 1.

1.8 All of the identified documents have a specific focus and address specific user needs. Nevertheless, IALA also recognized that there is a need for a high level document that consolidates all of technical and operational aspects of the sub-systems described in Figure 1. Consequently, IALA is at this time also drafting a general IALA Guideline on AIS which will incorporate all of the elements in Figure 1 in a descriptive manner.

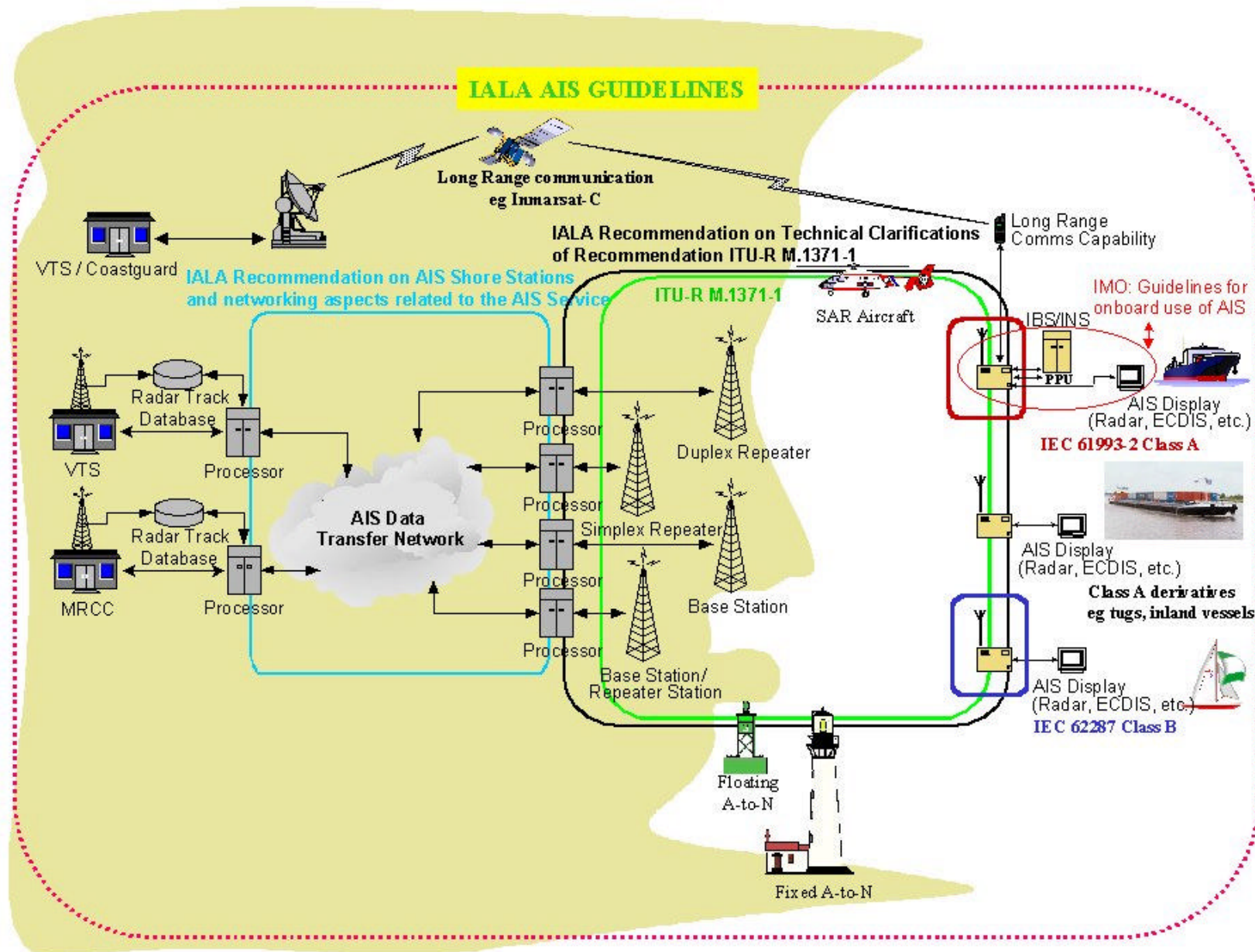

## 2 Technical Clarifications of ITU-R M.1371-1

### Important General Remark

Every clarification of this Chapter is presented in a uniform way:

- Every clarification is introduced in the appropriate context of Recommendation ITU-R M.1371-1, which is always quoted as a whole section. This is done to ensure, that all clarifications are to be understood in their appropriate context.
- The verbatim text of Recommendation ITU-R M.1371-1 is given in italics; additions by the clarification are given upright and underlined as of previous clarification editions and upright and double underlined in the present edition. Deleted text portions are identified with ~~strike-out as of previous clarification editions and double strike-out in the present edition~~.
- For every clarification a rationale is given to allow complete understanding as to why a clarification was needed also. Eventually, the clarifications will be incorporated into a future revision of Recommendation ITU-R M.1371-1).
- A date of when the clarification was drafted is given.
- A comment contains additional information on the clarification itself. For instance, some clarifications have already been incorporated in the first edition of the IEC standard for Class A shipborne mobile AIS stations (IEC standard 61993-2). A future substantial change of the clarification result in the creation of a legacy issue. Any future change for those clarifications should therefore be done with the utmost caution.

### 2.1 A1; § 4.2.1 Reporting Rate

#### 2.1.1 Proposed Clarifying Text

*The different information types are valid for a different time period and thus need a different update rate.*

*Static information: Every 6 min or, when data has been amended, on request.*

*Dynamic information: Dependent on speed and course alteration according to Tables 1A and B.*

*Voyage related information: Every 6 min or, when data has been amended, on request.*

*Safety related message: As required.*

TABLE 1A

*Class A Shipborne Mobile Equipment reporting intervals*

<i>Ship's Dynamic Conditions</i>	<i>Nominal Reporting Interval</i>
<i>Ship at anchor or moored and not moving faster than 3 knots</i>	<i>3 minutes<sup>(1)</sup></i>
<i>Ship at anchor or moored and moving faster than 3 knots</i>	<i>10 seconds<sup>(1)</sup></i>
<i>Ship 0-14 knots</i>	<i>10 seconds<sup>(1)</sup></i>
<i>Ship 0-14 knots and changing course</i>	<i>3<sup>1</sup>/<sub>3</sub> seconds<sup>(1)</sup></i>
<i>Ship 14-23 knots</i>	<i>6 seconds<sup>(1)</sup></i>

<i>Ship 14-23 knots and changing course</i>	<i>2 seconds</i>
<i>Ship &gt; 23 knots</i>	<i>2 seconds</i>
<i>Ship &gt; 23 knots and changing course</i>	<i>2 seconds</i>

<sup>(1)</sup> *When a mobile station determines that it is the semaphore (refer to Annex 2, § 3.1.1.4), the reporting rate should increase to once per 2 seconds (refer to Annex 2, § 3.1.3.3.2).*

*NOTE – These values have been chosen to minimize unnecessary loading of the radio channels while maintaining compliance within the IMO AIS performance standards*

Note 2: If the autonomous mode requires a higher reporting rate than the assigned mode, the Class A shipborne mobile AIS station should use the autonomous mode.

**TABLE 1B**

**Reporting intervals for equipment other than Class A Shipborne Mobile Equipment**

<i>Platform's Condition</i>	<i>Nominal Reporting Interval</i>
<i>Class B Shipborne Mobile Equipment not moving faster than 2 knots</i>	<i>3 minutes</i>
<i>Class B Shipborne Mobile Equipment moving 2-14 knots</i>	<i>30 seconds</i>
<i>Class B Shipborne Mobile Equipment moving 14-23 knots</i>	<i>15 seconds</i>
<i>Class B Shipborne Mobile Equipment moving &gt; 23 knots</i>	<i>5 seconds</i>
<i>Search and Rescue aircraft (airborne mobile equipment)</i>	<i>10 seconds</i>
<i>Aids to Navigation</i>	<i>3 minutes</i>
<i>AIS base station<sup>(2)</sup></i>	<i>10 seconds</i>

<sup>(1)</sup> When a mobile station determines that it is the semaphore (refer to Annex 2, § 3.1.1.4), the reporting rate should increase to once per 2 seconds (refer to Annex 2, § 3.1.3.3.2).

<sup>(2)</sup> *The base station rate should increase to once per 3<sup>1</sup>/<sub>3</sub> seconds after the station detects that one or more stations are synchronizing to the base station (refer to Annex 2, § 3.1.3.3.1)*

## 2.1.2 Rationale for Clarification:

1.) Note 2 is required due to a clarification of IMO to its performance standards for Class A shipborne mobile station (refer to IMO/NAV47/WP.3/Add.1, Annex1, page 4, last sentence of last paragraph of Chapter 3): "The shore station can only increase the ships' reporting rate but not decrease it". It requires, that the reporting rate of a Class A shipborne mobile station must be determined by that mobile station autonomously when this would require a higher reporting rate, e. g. due to the current change of speed or course, even when originally assigned a lower reporting rate by a base station. This might not be required by the VTS, to which the base station belongs, but it is of relevance to the ship-to-ship relationship. A required higher

reporting rate due to a pending increase of speed and/or changing course can be known instantaneously only by the Class A shipborne mobile station itself.

[2.) Class B can be used as a semaphore]

2.1.3 Date of amendment: Edition 1.0: 10.2001; Edition 1.4: 09.2003

2.1.4 Comment

This clarification has been incorporated in the IEC Standard 61993-2 for Class A shipborne mobile AIS stations. Any future change to this clarification should consider not to create a legacy issue.

## 2.2 A2; § 1 Structure of this annex

### 2.2.1 Proposed Clarifying Text

#### 1 *Structure of ~~this annex~~ the AIS*

##### 1.1 AIS Layer Module

*This standard covers layers 1 to 4 (Physical Layer, Link Layer, Network Layer, Transport Layer) of the Open System Interconnection (OSI) model. The following figure illustrates the layer model of an AIS station (Physical Layer to Transport Layer) and the layers of the applications (Session Layer to Application Layer):*

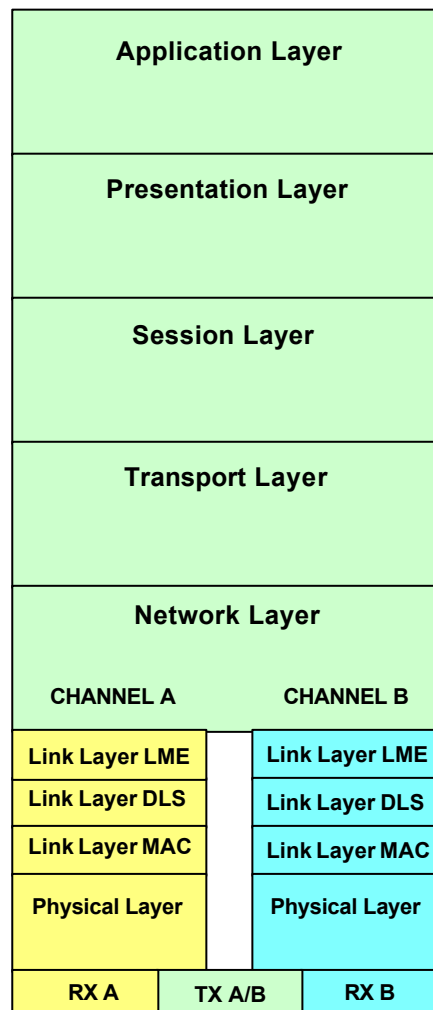

1.2 Responsibilities of AIS Layers for preparing AIS data for transmission

1.2.1 The Transport Layer is responsible for converting data into transmission packets of correct size and sequencing of data packets.

1.2.2 The Network Layer is responsible for the management of priority assignments of messages, distribution of transmission packets between channels, and data link congestion resolution.

1.2.3 The Link Layer is divided into three sublayers with the following tasks:

1.2.3.1 Link Management Entity (LME)

Assemble AIS message bits, ref. § 3.3.8

Order AIS message bits into 8-bit bytes for assembly of transmission packet, ref. § 3.3.7

1.2.3.2 Data Link Services (DLS)

Calculate FCS for AIS message bits, ref. § 3.2.2.6

Append FCS to AIS message to complete creation of transmission packet contents, ref. § 3.2.2.2

Apply bit stuffing process to transmission packet contents, ref. § 3.2.2.1

Complete assembly of transmission packet, ref. § 3.2.2.2

1.2.3.3 Media Access Control (MAC)

Provides a method for granting access to the data transfer to the VHF data link (VDL). The method used is a Time Division Multiple Access (TDMA) scheme using a common time reference.

1.2.4 Physical Layer

NRZI encode assembled transmission packet, ref. § 2.4.1.1 or § 2.7

Convert digital NRZI coded transmission packet to analog GMSK signal to modulate transmitter, ref. 2.4.1.1

2.2.2 Rationale for Clarification:

The present draft contains the layered structure of the AIS OSI/ISO layer stack. While all layers are described in detail in the appropriate sections, an overview on the most important functions of those layers was required. This also describes, what order should be observed when assembling an AIS message on the transmitting side, i. e. the process takes place from top to bottom of the layer stack; on the receiving side, the process takes place from the bottom of the layer stack upwards.

2.2.3 Date of amendment: 10.2001

2.2.4 Comment

No comment

## 2.3 A2; § 2.3 Transceiver characteristics

### 2.3.1 Proposed Clarifying Text

*The transceiver should perform in accordance with the characteristics set forth herein.*

#### **Class A Shipborne Mobile Equipment**

The technical characteristics as specified in Table A shall apply to the TDMA receivers for Class A Shipborne Mobile Equipment.

**Table A: Required receiver characteristics for Class A Shipborne Mobile Equipment**

<u>Receiver Parameters</u>	<u>25kHz channels</u>	<u>12.5kHz channels</u>
<u>Sensitivity</u>	<u>20% PER for -107 dBm</u>	<u>20% PER for -98 dBm</u>
<u>Co-channel rejection</u>	<u>-10 – 0 dB</u>	<u>-18 – 0 dB</u>
<u>Adjacent channel selectivity</u>	<u>70 dB</u>	<u>50 dB</u>
<u>Spurious response rejection</u>	<u>70 dB</u>	<u>N/A</u>
<u>Intermodulation response rejection and Blocking</u>	<u>20 % PER</u>	<u>N/A</u>

### 2.3.2 Rationale for Clarification:

The M.1371-1 does not contain any definition for receiver characteristics. From an AIS VDL system point of view, it is considered important to have receiver characteristics for all kind of AIS stations.

For this edition only Class A shipborne mobile AIS station's receiver characteristics have been included.

2.3.3 Date of amendment: Edition 1.0: 10.2001; Edition 1.3: 09.2002

### 2.3.4 Comment

This clarification has been incorporated in the IEC Standard 61993-2 for Class A shipborne mobile AIS stations. Any future change to this clarification should consider not to create a legacy issue.

## 2.4 A2; §3.1.1.3 Synchronized to base station (Direct or Indirect)

### 2.4.1 Proposed Clarifying Text

*Mobile stations, which are unable to attain direct or indirect UTC synchronization, but are able to receive transmissions from base stations, should synchronize to the base station which indicates the highest number of received stations, provided that two reports have been received from that station in the last 40 seconds. Once base station synchronization has been established, this synchronization shall be discontinued if fewer than two reports are received from the selected base station in the last 40 seconds. When the parameter SlotTimeOut of the SOTDMA Communication State has one of the values three (3), five (5), or seven (7), the number of received stations should be contained within the SOTDMA Communication State-Submessage. The station which is thus synchronized to a Base Station should then change its synchronization state to "base station" to reflect this. A station that has Sync.State = 3 (see 3.1.3.4.3) shall synchronize to a station that has*

Sync.State = 2 (see 3.1.3.4.3) if no base station or station with UTC direct is available. Only one level of indirect access to the base station is allowed. When a station is receiving several other base stations which indicate the same number of received stations, synchronization should be based on the station with the lowest MMSI.

2.4.2 Rationale for Clarification:

It is also possible for a station to synchronize to a base station indirect.

2.4.3 Date of amendment: 10.2001

2.4.4 Comment

2.5 A2; §3.1.3.3 Synchronization - Transmitting stations (see Figure 1)

2.5.1 Proposed Clarifying Text

FIGURE 1

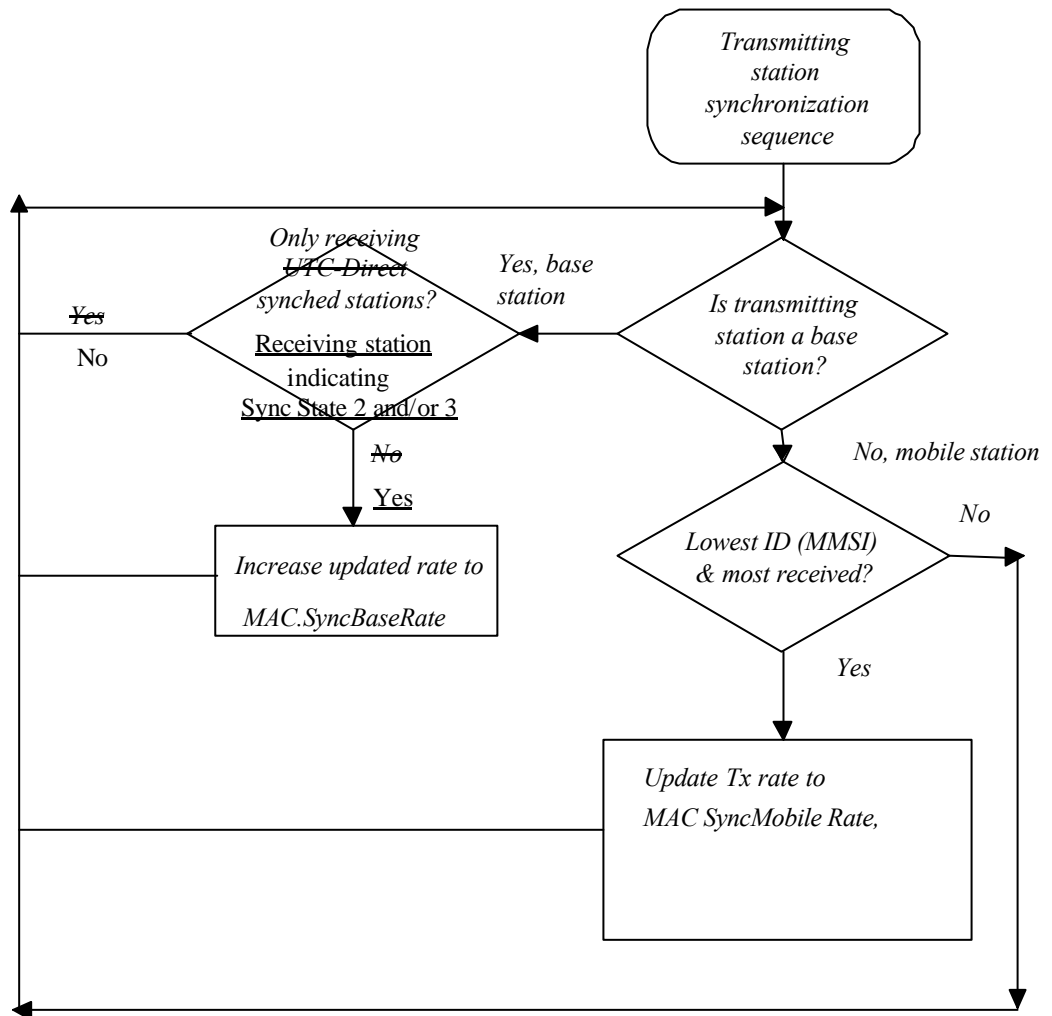

2.5.2 Rationale for Clarification:

There was no definition for being "semaphore qualified" in M.1371-1. It was concluded, that this definition would be best rendered by one table for mobiles and one table for base stations.

2.5.3 Date of amendment: 10.2001

2.5.4 Comment

No Comment

## **2.6 A2; § 3.1.3.3.1 Base station operation**

2.6.1 Proposed Clarifying Text

*The base station should normally transmit the Base Station Report (Message 4) with a minimum reporting rate of 10 seconds.*

*The base station should ~~operate in this state until it detects one or more stations that are synchronizing to the base station. It should then increase its update rate of Message 4 to MAC.SyncBaseRate~~ increase its update rate of message 4 to MAC.SyncBaseRate when it fulfils the semaphore qualifying conditions according to the table in 3.1.3.4.3. It should remain in this state until no stations have indicated synchronizing to the base station until the semaphore qualifying conditions has been invalid for the last 3 minutes.*

2.6.2 Rationale for Clarification:

There was no definition for being "semaphore qualified" in M.1371-1. It was concluded, that this definition would be best rendered by one table for mobiles and one table for base stations.

2.6.3 Date of amendment: 10.2001

2.6.4 Comment

No Comment

## **2.7 A2; §3.1.3.3.2 Mobile station operation as a semaphore**

2.7.1 Proposed Clarifying Text

*When a mobile station determines that it is the semaphore (see § 3.1.1.4 and 3.1.3.4.3), it should increase its update rate to MAC.SyncMobileRate. It should remain in this state until the semaphore qualifying conditions have been invalid for the last 3 minutes.*

2.7.2 Rationale for Clarification:

There was missing a condition for the termination of the state of acting as a semaphore. The condition and a hysteresis was introduced.

2.7.3 Date of amendment: 10.2001

2.7.4 Comment

This clarification has been incorporated in the design and tests of Class A shipborne mobile AIS stations. Any future change to this clarification should consider not to create a legacy issue.

**2.8 A2; § 3.1.3.4 Synchronization - Receiving stations (see Figure 2)**

2.8.1 Proposed Clarifying Text

Figure 2

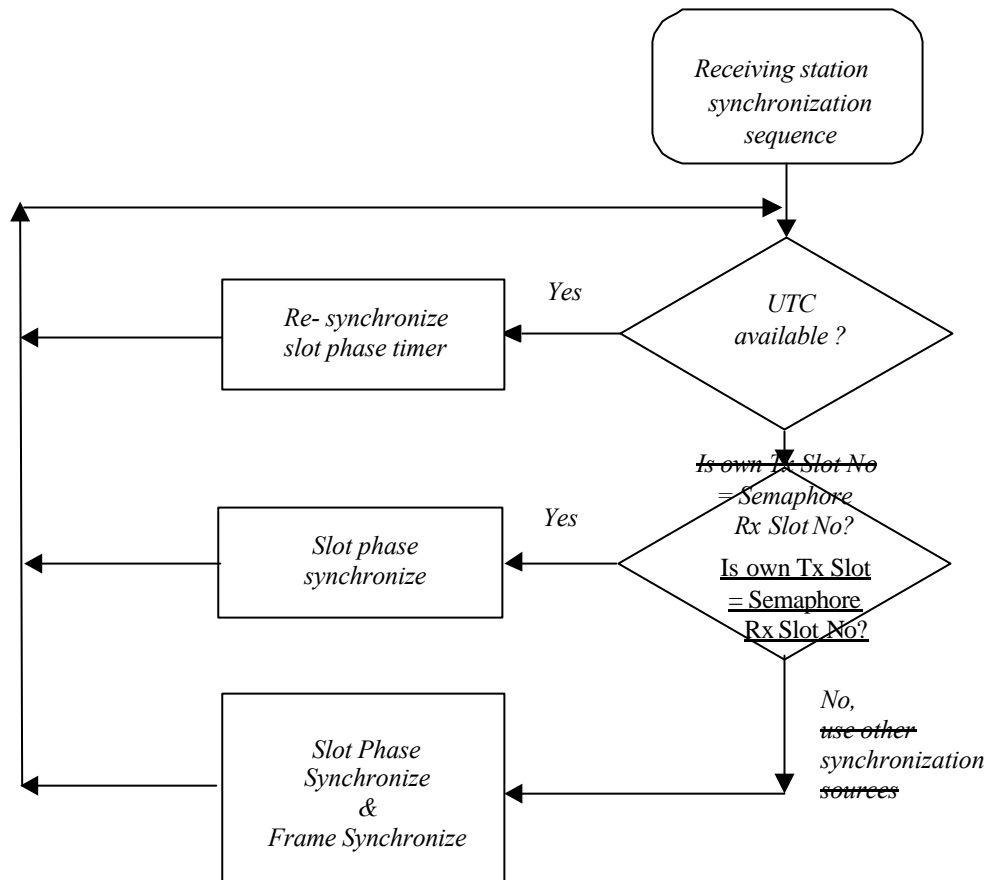

2.8.2 Rationale for Clarification:

2.8.3 Date of amendment: 10.2001

2.8.4 Comment

**2.9 A2; § 3.1.3.4.1 UTC available**

2.9.1 Proposed Clarifying Text

*A station, which has direct ~~or indirect~~ access to UTC, should continuously re-synchronize its transmissions based on ~~the~~ UTC source. A station, which has indirect access to UTC should continuously re-synchronize, its transmissions based on those UTC sources (refer to 3.1.1.2).*

2.9.2 Rationale for Clarification:

Inconsistency in M.1371-1.

2.9.3 Date of amendment: 10.2001

2.9.4 Comment

This clarification has been incorporated in the design and tests of Class A shipborne mobile AIS stations. Any future change to this clarification should consider not to create a legacy issue.

## **2.10 A2; § 3.1.3.4.2 Own transmission slot number equal to the received semaphore slot number**

2.10.1 Proposed Clarifying Text

**3.1.3.4.2 UTC not available** ~~Own transmission slot number equal to the received semaphore slot number~~

*When the station determines that its own internal slot number is equal to the semaphore slot number, it is already in Frame Synchronization and it should continuously slot phase synchronize.*

2.10.2 Rationale for Clarification:

The paragraph does not point out, that it applies under the condition when UTC is not available directly or indirectly. The new paragraph heading clarifies this point.

2.10.3 Date of amendment: 10.2001

2.10.4 Comment:

This clarification has been incorporated in the design and tests of Class A shipborne mobile AIS stations. Any future change to this clarification should consider not to create a legacy issue.

## **2.11 A2; § 3.1.3.4.3 Other synchronization sources**

2.11.1 Proposed Clarifying Text

~~§ 3.1.3.4.3 Other s~~Synchronization sources

~~Other possible~~ The primary source for synchronisation should be the integral UTC source (UTC Direct). If this source should be unavailable the following external synchronization sources, which can listed below in the order of priority should serve as the basis for Slot Phase and Frame Synchronizations, are listed below in the order of priority:

- 1) *A station which has UTC time.*
- 2) *A base station which is semaphore qualified.*
- 3) *Other station(s) which are synchronized to a base station.*
- 4) *A mobile station, which is semaphore qualified.*

~~See § 3.1.1.4 for semaphore qualification. A station is semaphore qualified if it is indicating the most number of received stations. If more than one indicates the same amount, the one with the lowest identifier rules. The station with the highest syne state can also be semaphore qualified if that is the sole station with that syne state.~~

The following table illustrates the different Sync Mode priorities and the contents of the Sync State fields in the Communication State.

**Synchronization Mode**

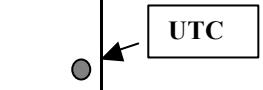
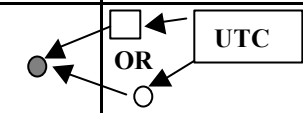
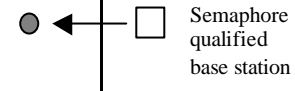
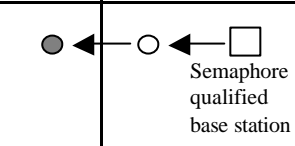
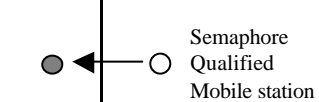
<u>Sync Mode of Own Station</u>	<u>Priority</u>	<u>Illustration</u>	<u>Sync State (in CommState) of own station</u>	<u>May be used as source for indirect sync by other station(s)</u>
<u>UTC direct</u>	<u>1</u>		<u>0</u>	<u>Yes</u>
<u>UTC indirect</u>	<u>2</u>		<u>1</u>	<u>No</u>
<u>Base direct</u>	<u>3</u>		<u>2</u>	<u>Yes</u>
<u>Base indirect</u>	<u>4</u>		<u>3</u>	<u>No</u>
<u>Mobile as semaphore</u>	<u>5</u>		<u>3</u>	<u>No</u>

A mobile station should only be semaphore qualified under following condition:

		<u>Highest Received synchronisation state value</u>			
<u>Mobile stations synchronisation state value</u>	<u>Own mobile station's sync state</u>	<u>0</u>	<u>1</u>	<u>2</u>	<u>3</u>
	<u>0</u>	<u>No</u>	<u>No</u>	<u>No</u>	<u>No</u>
	<u>1</u>	<u>No</u>	<u>No</u>	<u>No</u>	<u>Yes</u>
	<u>2</u>	<u>No</u>	<u>No</u>	<u>No</u>	<u>No</u>
	<u>3</u>	<u>No</u>	<u>Yes No</u>	<u>No</u>	<u>Yes</u>

0 = UTC Direct (refer to § 3.1.1.1).

1 = UTC Indirect (refer to § 3.1.1.2).

2 = Station is synchronized to a Base station (refer to § 3.1.1.3).

3 = Station is synchronized to another station based on the highest number of received stations (refer to § 3.1.1.4) or indirect to a base station:

If more than one station is semaphore qualified, then the station indicating the highest number of received stations should become the active semaphore station. If more than one station indicates the same number of received stations, then the one with the lowest MMSI number rules.

A base station should only be semaphore qualified under following condition:

<u>Base stations synchronisation state value</u>	<u>Own base station's sync state</u>	<u>Highest Received synchronisation state value</u>			
		<u>0</u>	<u>1</u>	<u>2</u>	<u>3</u>
	<u>0</u>	<u>No</u>	<u>No</u>	<u>No</u>	<u>No</u>
	<u>1</u>	<u>No</u>	<u>No</u>	<u>Yes</u>	<u>Yes</u>
	<u>2</u>	<u>No</u>	<u>No</u>	<u>Yes</u>	<u>Yes</u>
	<u>3</u>	<u>N.A No</u>	<u>N.A No</u>	<u>N.A Yes</u>	<u>N.A Yes</u>

0 = UTC Direct (refer to § 3.1.1.1).

1 = UTC Indirect (refer to § 3.1.1.2).

2 = Station is synchronized to a Base station (refer to § 3.1.1.3).

3 = Station is synchronized to another mobile station based on the highest number of received stations (refer to § 3.1.1.4) or indirect to a base station:

A base station which is semaphore qualified according to the table above should act as a semaphore.

See also § 3.1.1.4 , 3.1.1.3 and 3.1.3.3 for semaphore qualification."

#### 2.11.2 Rationale for Clarification:

There was no definition for being "semaphore qualified" in M.1371-1. It was concluded, that this definition would be best rendered by one table for mobiles and one table for base stations.

2.11.3 Date of amendment: Edition 1.0: 10.2001; Edition 1.3: 09.2002

#### 2.11.4 Comment:

This clarification has been incorporated in the design and tests of Class A shipborne mobile AIS stations as far as mobile stations are affected. Any future change to this clarification should consider not to create a legacy issue.

## 2.12 A2; §3.1.6 Slot State

### 2.12.1 Proposed Clarifying Text:

*Each slot can be in one of the following states:*

- 1) *FREE: meaning that the slot is unused within the receiving range of the own station. Externally Allocated slots that have not been used during the preceding 3 frames are also FREE slots. This slot may be considered as a candidate slot for use by own station (refer to 3.3.1.2);*
- 2) *INTERNAL ALLOCATION: meaning that the slot is allocated by own station and can be used for transmission;*
- 3) *EXTERNAL ALLOCATION: meaning that the slot is allocated for transmission by another station ~~and cannot be used by own station;~~*
- 4) *AVAILABLE: meaning that the slot is externally allocated by a ~~distant~~ station and is a possible candidate for slot reuse (refer to § 4.4.1).*  
*UNAVAILABLE: meaning that the slot is externally allocated by a station and cannot be a candidate for slot reuse (refer to § 4.4.1).*

2.13 Rationale for Clarification:

External slot allocation results in two types of slot availability. Both of these slot availability types need to be defined.

2.14 Date of amendment: Edition 1.4: 09.2003

2.15 Comment

**2.16 A2; § 3.2.2.1 Bit stuffing**

2.16.1 Proposed Clarifying Text:

*The bit stream of the data portion and the FCS, refer to Figure 4, § 3.2.2.5 and § 3.2.2.6, should be subject to bit stuffing. On the transmitting side this ~~This~~ means that if five (5) consecutive ones (1s) are found in the output bit stream, a zero should be inserted after the five (5) consecutive ones (1s). This applies to all bits between the ~~except the data bits of~~ HDLC flags (Start flag and End flag, see Figure 4) on the receiving side the first zero after five (5) consecutive ones (1s) should be removed.*

2.16.2 Rationale for Clarification

Two clarifications are combined:

- The order in which the operations are performed is essential for proper function. Since the original description could have been applied both to the transmitting and the receiving side, a clarification was needed. This description applies to the transmitting side. On the receiving side, the process should be performed in reverse order.
- There was clarification needed as to where the zero bit due to bit stuffing was to be put in the output data stream.

2.16.3 Date of amendment: 10.2001

2.16.4 Comment

This clarification has been incorporated in the design and tests of Class A shipborne mobile AIS stations as far as mobile stations are affected. Any future change to this clarification should consider not to create a legacy issue.

**2.17 A2; § 3.2.2.8.1 Bit stuffing**

2.17.1 Proposed Clarifying Text:

*A statistical analysis of all possible bit combinations in the data field of the fixed length messages shows that 76% of combinations use 3 bits or less, for bit stuffing. Adding the logically possible bit combinations shows, that 4 bits are sufficient for these messages. Where variable length messages are used, additional bit stuffing could be required. For the case where additional bit stuffing is required, refer to ~~§ 5.3.1~~ §5.2 and Table 36.*

2.17.2 Rationale for Clarification:

Wrong reference.

2.17.3 Date of amendment: 10.2001

2.17.4 Comment

No comment

## 2.18 A2; §3.3.1.2 Candidate slots

### 2.18.1 Proposed Clarifying Text:

*Slots, used for transmission, are selected from candidate slots in the selection interval (SI), refer to Figure 9. The selection process uses received data. There should always be at minimum four candidate slots to choose from unless the number of candidate slots is otherwise restricted due to loss of position information (see § 4.4.1). For Class A mobile AIS station ~~When~~ when selecting candidates for messages longer than one (1) slot (refer to §3.2.2.11) a candidate slot should be the first slot in a consecutive block of free or available reusable slots. For Class B mobile AIS stations the candidate slots for message 6, 8, 12, 14, should be free. ]When no candidate slot is available, the use of the current slot is allowed. The candidate slots are primarily selected from free slots (see § 3.1.6). When required, available slots are included in the candidate slot set. When selecting a slot from the candidates, any candidate has the same probability of being chosen, regardless of its slot state (refer to § 3.1.6). If the station cannot find any candidate slots at all, because all slots in the SI are restricted from slot reuse (refer to §4.4.1), the station should not reserve a slot in the SI until there is at least one candidate slot to transmit.*

Example:

<u>0</u>	<u>1</u>	<u>2</u>	<u>3</u>	<u>4</u>	<u>5</u>	<u>6</u>	<u>7</u>
<u>E</u>	<u>E</u>	<u>F</u>	<u>F</u>	<u>F</u>	<u>F</u>	<u>F</u>	<u>E</u>

A three-slot-message is to be sent. Only slots Nos. 2, 3 and 4 should be considered candidates.

*When selecting among candidate slots for transmission in one channel, the slot usage of other channels should be considered. If the candidate slot in the other channel is used by another station, the use of the slot should follow the same rules as for slot reuse (refer to § 4.4.1). If a slot in either channel is occupied by or allocated by other base or mobile station, that slot should be reused only in accordance with § 4.4.1.*

*The slots of another station, whose navigational status is not set to "at anchor" or "moored" and has not been received for 3 minutes, should be used as candidate slots for intentional slot reuse.*

*The own station is unable to transmit on an adjacent slot on the two parallel channels because of the necessary switching time (refer to § 2.12.4). Thus, the two adjacent slots on either side of a slot that is being used by the own station on one channel should not be considered as candidate slots on the other channel.*

*The purpose of intentionally reusing slots and maintaining a minimum of four candidate slots within the same probability of being used for transmission is to provide high probability of access to the link. To further provide high probability of access, time-out characteristics are applied to the use of the slots so that slots will continuously become available for new use.*

*Figure 7 illustrates the process of selecting among candidate slots for transmission on the link.*

FIGURE 7

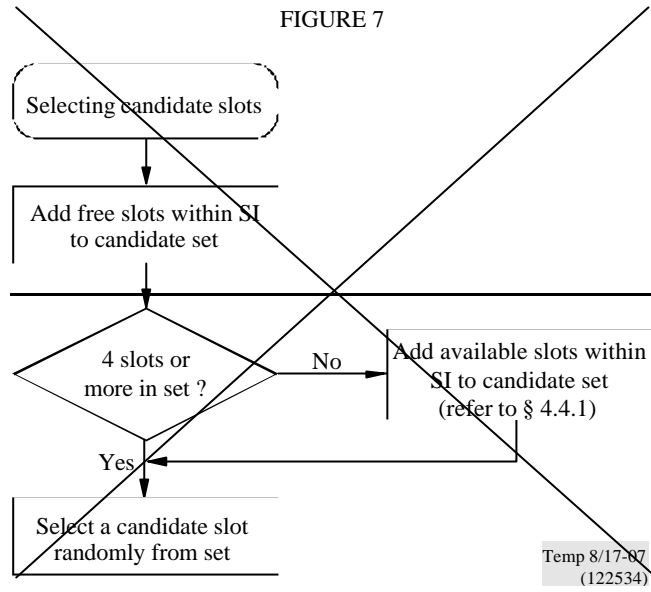

FIGURE 7 (new)

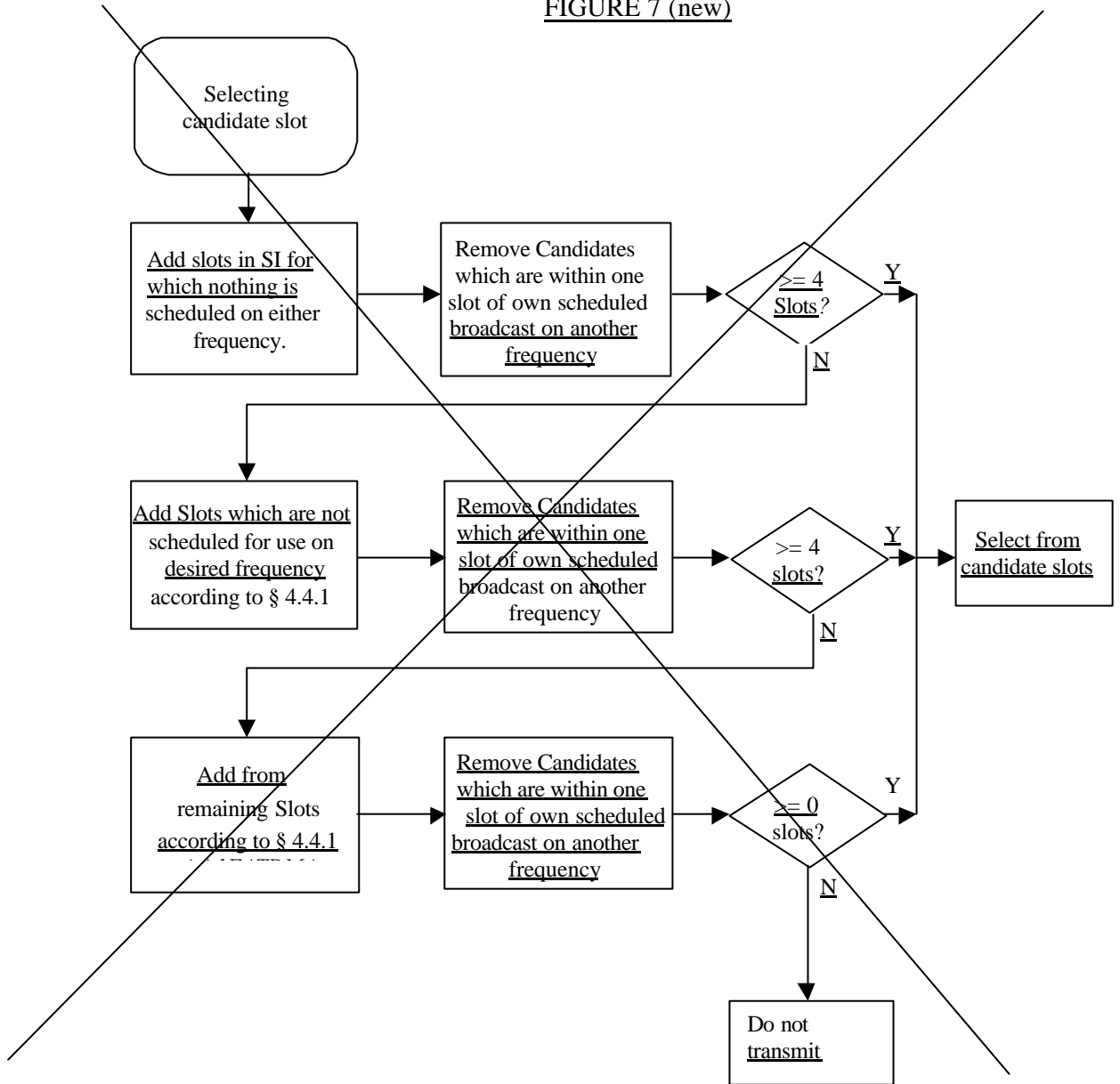
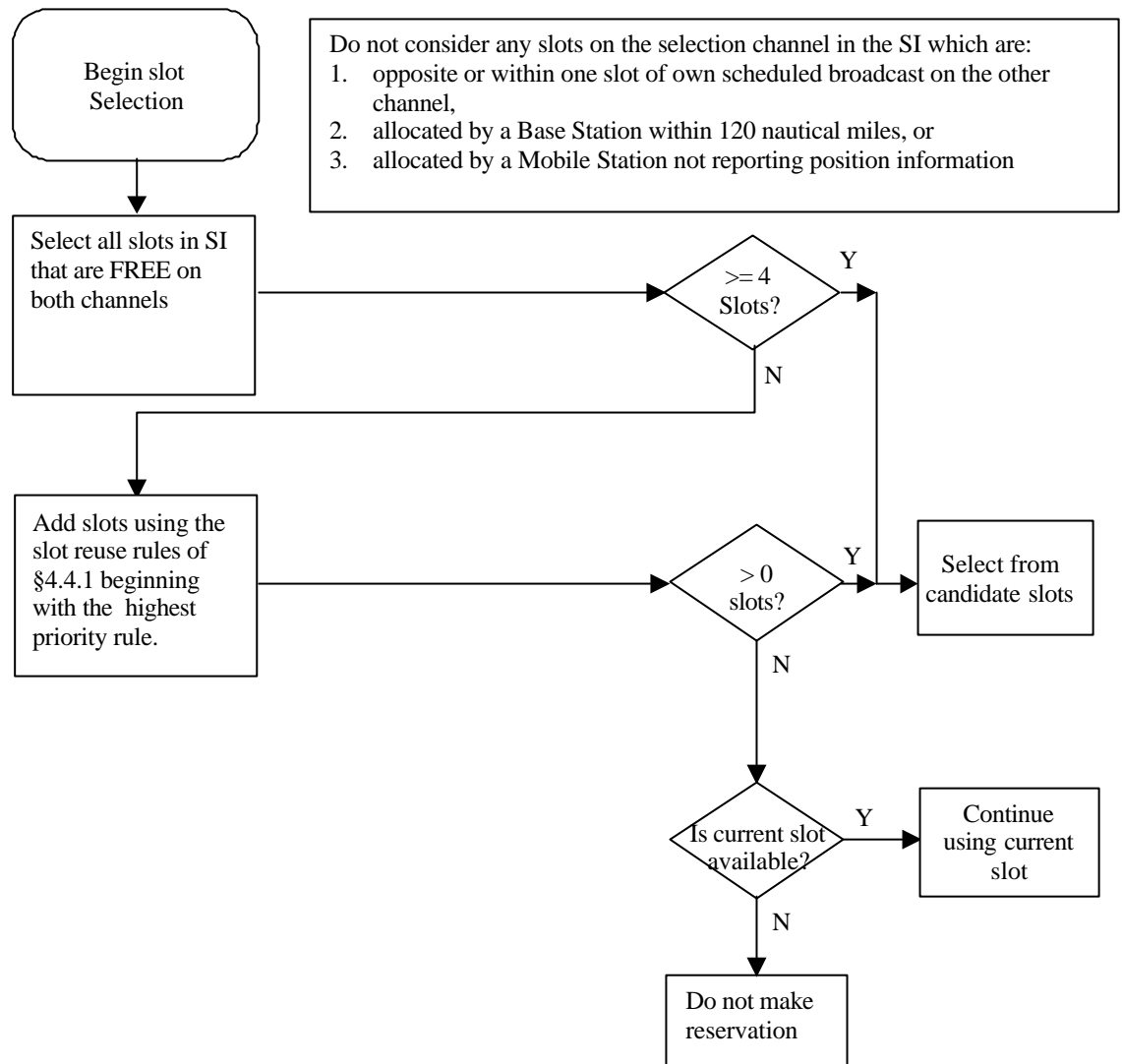

FIGURE 7 (~~new~~ revised)



### 2.18.2 Rationale for Clarification:

- 1.) A rule is needed to optimize the slot allocation process for long transmissions (longer than 1 slot) when selecting candidate slots for long transmission packets.
- 2.) Slots, used for transmission, are selected from candidate slots in the selection interval (SI). Under circumstances, which must be considered very unlikely, the slot selection algorithm may not find a candidate slot according to the existing rules within the SI. This situation applies for all messages. The reason for this condition may be:

- One or more base station(s) has/have allocated large blocks (7 slots or more) with msg 20 that can cover the SI for a mobile.
- Several stations, which report "No position available" cover the SI.

Resulting requirements (=rationale): There must be a defined behaviour if there is no candidate slot. This condition will not appear under normal conditions. The additional flow-chart provides a detailed graphical representation of the whole slot selection algorithm.

1. Words were added to recognize that received data and signal information can also be used in the slot selection process.
2. Wording was changed to improve the precision of the material.
3. Figure 7 was revised to:
  - clarify the slots that cannot be considered for reuse,
  - simplify the diagram, and
  - improve clarity.

[Class B mobile AIS stations must use free slots for transmitting msg 6, 8, 12, 14.]

2.18.3 Date of amendment: 10.2001; Edition 1.4 09.2003

2.18.4 Comment

This clarification has been incorporated in the design and tests of Class A shipborne mobile AIS stations as far as mobile stations are affected. Any future change to this clarification should consider not to create a legacy issue.

## **2.19 A2; §3.3.2 Modes of operation**

2.19.1 Proposed Clarifying Text

*There should be three modes of operation. The default mode should be autonomous and may be switched to/from other modes as required by a competent authority. For a Simplex Repeater there should only be two modes of operation: autonomous and assigned, but no polled mode.*

2.19.2 Rationale for Clarification

A simplex repeater stores and forwards only messages received from other stations. A simplex repeater is not to be considered a genuine source of messages. A simplex repeater does not create its own messages. Therefore, it cannot be interrogated.

2.19.3 Date of amendment: 10.2001

2.19.4 Comment

No comment

## **2.20 A2; §3.3.2.1 Autonomous and continuous**

2.20.1 Proposed Clarifying Text

*A station operating autonomously should determine its own schedule for transmission ~~of its position~~. The station should automatically resolve scheduling conflicts with other stations.*

2.20.2 Rationale for Clarification:

The transmission schedule is determined autonomously not only for position reports but for any autonomously transmitted messages.

2.20.3 Date of amendment: 10.2001

2.20.4 Comment

No comment

## **2.21 A2; § 3.3.2.2 Assigned**

2.21.1 Proposed Clarifying Text

*A station operating in the assigned mode should use a transmission schedule assigned by a competent authority's base ~~or repeater~~ station.*

### 2.21.2 Rationale / Reason for Clarification

Separation of functionality of Base Station and Repeater. If a combined Base/Repeater Station is transmitting Msg. 16 then it is due to the Base Station functionality

2.21.3 Date of amendment: 10.2001

2.21.4 Comment

No comment

## 2.22 A2 §3.3.4.2.1 RATDMA algorithm

### 2.22.1 Proposed Clarifying Text

*The RATDMA access scheme should use a probability persistent (p-persistent) algorithm as described in this paragraph (see Table 7).*

*Messages, which use the RATDMA access scheme, are stored in a priority first-in first-out (FIFO). When a candidate slot (see § 3.3.1.2) is detected, the station randomly select a probability value (LME.RTP1) between 0 and 100. This value should be compared with the current probability for transmission (LME.RTP2). If LME.RTP1 is equal to, or less than LME.RTP2, transmission should occur in the candidate slot. If not, LME.RTP2 should be incremented with a probability increment (LME.RTP1) and the station should wait for the next candidate slot in the frame.*

*The SI for RATDMA should be 150 time slots, which is equivalent to 4s. The candidate slot set should be chosen within the SI, so that the transmission occurs within 4 s.*

**[No SI limit is set for Class B. Class B should avoid using RATDMA. Class B should use a message 18 slot reservation to announce a future slot reservation by using the message 18 ITDMA ComState.]**

*Each time that a candidate slot is entered, the p-persistent algorithm is applied. If the algorithm determines that a transmission shall be inhibited, then the parameter LME.RTCSC is decremented by one and LME.RTA is incremented by one.*

*LME.RTCSC can also be decremented as a result of another station allocating a slot in the candidate set. If  $LME.RTCSC + LME.RTA < 4$  then the candidate set shall be complemented with a new slot within the range of the current slot and LME.RTES following the slot selection criteria.*

### 2.22.2 Rationale / Reason for Clarification

This is due to reduce the use of RATDMA access of Class B stations.

2.22.3 Date of amendment: Edition 1.4: 09.2003

2.22.4 Comment

No comment

## 2.23 A2; § 3.3.4.4 Self-Organizing TDMA - SOTDMA

### 2.23.1 Proposed Clarifying Text

*The SOTDMA access scheme should be used by mobile stations operating in autonomous and continuous mode, or in the assigned mode (refer to Table 13).*

*The purpose of the access scheme is to offer an access algorithm which quickly resolves conflicts without intervention from controlling stations.*

*Messages which use the SOTDMA access scheme are of a repeatable character and are used in order to supply a continuously updated surveillance picture to other users of the data link.*

2.23.2 Rationale for Clarification

2.23.3 Date of amendment: 10.2001

2.23.4 Comment

**2.24 A2; § 3.3.4.4.2 SOTDMA parameters**

2.24.1 Proposed Clarifying Text

*The following parameters control SOTDMA scheduling:*

TABLE 9

Symbol	Name	Description	Minimum	Maximum
NSS	Nominal start slot	<i>This is the first slot used by a station to announce itself on the data link. Other repeatable transmissions are generally selected with the NSS as a reference.</i>  <i>When transmissions with the same reporting rate (Rr) are made using two channels ("A" and "B"), the NSS for the second channel ("B") is offset from the first channel's NSS by NI:</i>  $NSS_B = NSS_A + NI$	0	2 249
NS	Nominal slot	<i>The nominal slot is used as the centre around which slots are selected for transmission of position reports. For the first transmission in a frame, the NSS and NS are equal. The NS when using only one channel is:</i>  $NS = NSS + (n \cdot NI); (0 \leq n < Rr)$  <i>When transmissions are made using two channels ("A" and "B"), the slot separation between the nominal slots on each channel is doubled and offset by NI:</i>  $NS_A = NSS_A + (n \cdot 2 \cdot NI);$ <i>where <math>0 \leq n &lt; 0.5 \cdot Rr</math></i>  $NS_B = NSS_A + NI + (n \cdot 2 \cdot NI);$ <i>where <math>0 \leq n &lt; 0.5 \cdot Rr</math></i>	0	2 249
NI	Nominal increment	<i>The nominal increment is given in number of slots and is derived using the equation below:</i>  $NI = 2\,250/Rr$	75 (4)	<del>1 225</del> 1 125
Rr	Report rate	<i>This is the desired number of position reports per frame minute. When a station uses a report rate of less than one report per frame, ITDMA allocations are used. Otherwise,</i>	<del>1/3</del> 2 (1) (2)	30 (3)

		<i>SOTDMA is used.</i>		
<i>SI</i>	<i>Selection interval</i>	<i>Selection interval. The selection interval is the collection of slots which can be candidates for position reports. The SI is derived using the equation below: <math>SI = \{NS - (0.1 \cdot NI) \text{ to } NS + (0.1 \cdot NI)\}</math></i>	<i>0.2 · NI</i>	<i>0.2 · NI</i>
<i>NTS</i>	<i>Nominal transmission slot</i>	<i>The slot, within a selection interval, currently used for transmissions within that interval.</i>	<i>0</i>	<i>2 249</i>
<i>TMO_MIN</i>	<i>Minimum time-out</i>	<i>The minimum <del>number of frames that a SOTDMA allocation will occupy a specific slot</del> <u>time out</u>.</i>	<i>3</i>	<i>3</i>
<i>TMO_MAX</i>	<i>Maximum time-out</i>	<i>The maximum <del>number of frames that a SOTDMA allocation will occupy a specific slot</del> <u>time out</u>.</i>	<del><i>TMO_MIN</i></del> <i>7</i>	<del><i>8</i></del> <i>7</i>

Footnote:

- (1) When a station uses a report rate of less than two reports per minute, ITDMA allocations should be used  
(2) Also when operating in the assigned mode using SOTDMA as given by Table 13  
(3) 60 reports per minute when operating in the assigned mode using SOTDMA as given by Table 13  
(4) 37.5 when operating in the assigned mode using report rate assignment; 45 when operating in the assigned mode using slot increment assignment and SOTDMA CommState

2.24.2 Rationale for Clarification:

Consequential change to clarification of A2; § 3.3.6

2.24.3 Date of amendment: 10.2001

2.24.4 Comment:

This clarification has been incorporated in the design and tests of Class A shipborne mobile AIS stations as far as mobile stations are affected. Any future change to this clarification should consider not to create a legacy issue.

**2.25 A2; § 3.3.5.1.1 Monitor VHF data link (VDL)**

2.25.1 Proposed Clarifying Text

*At power on, a station should monitor the TDMA channel for one (1) minute interval to determine channel activity, other participating member IDs, current slot assignments and reported positions of other users, and possible existence of base stations. During this time period, a dynamic directory of all members operating in the system should be established. A frame map should be constructed, which reflects TDMA channel activity.*

2.25.2 Rationale for Clarification:

There has been inconsistency and therefore ambiguity with regard to the use of the concepts "frame" and "minute". This clarification removes this ambiguity: A "minute" is a time interval, which may start at any time. A "frame" is defined as starting from a fixed point in time, i.e. the start of any UTC minute. In particular, the initialization

phase of a station may start at any point in time, which can be in the middle of a frame, but it will always take one minute interval

2.25.3 Date of amendment: 10.2001

2.25.4 Comment:

No comment

## **2.26 A2; § 3.3.5.1.2 Network entry after one minute**

2.26.1 Proposed Clarifying Text

*After one (1) minute interval has elapsed, the station should enter the network and start to transmit according to its own schedule, as described below.*

2.26.2 Rationale for Clarification:

Refer to rational of clarification of A2 § 3.3.5.1.1 Monitor VHF data link (VDL)

2.26.3 Date of amendment: 10.2001

2.26.4 Comment:

No comment

## **2.27 A2; § 3.3.5.2 Network entry phase**

2.27.1 Proposed Clarifying Text

*During the network entry phase, the station should select its first slot for transmission in order to make itself visible to other participating stations. The first transmission should always be the ~~scheduled~~ special position report (Message3; refer to Figure 11).*

FIGURE 11

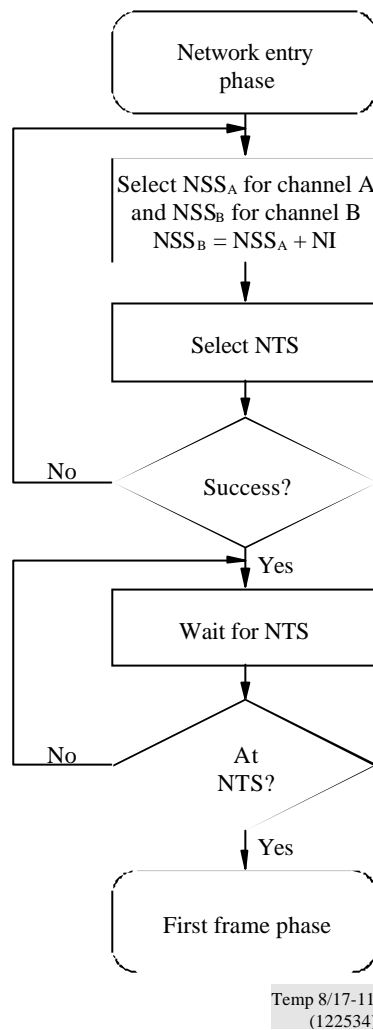

2.27.2 Rationale for Clarification:

Editorial; inconsistency of reference within M.1371-1

2.27.3 Date of amendment: 10.2001

2.27.4 Comment:

No comment

**2.28 A2; § 3.3.5.2.2 Select Nominal Transmission Slot (NTS)**

2.28.1 Proposed Clarifying Text

*Within the SOTDMA algorithm, the NTS should be randomly selected among candidate slots within the Selection Interval (SI). This is the NTS, which should be marked as internally allocated and assigned a random time-out between and including TMO\_MIN and TMO\_MAX.*

2.28.2 Rationale for Clarification

Clarifying time out value

2.28.3 Date of amendment: Edition 1.1:12.2001

2.28.4 Comment:

## 2.29 A2; § 3.3.5.3 First frame phase

### 2.29.1 Proposed Clarifying Text

*During the first frame phase which is equal to one minute interval, the station should continuously allocate its transmission slots and transmit ~~scheduled~~ special position reports (Message 3) using ITDMA (refer to Figure 12).*

FIGURE 12

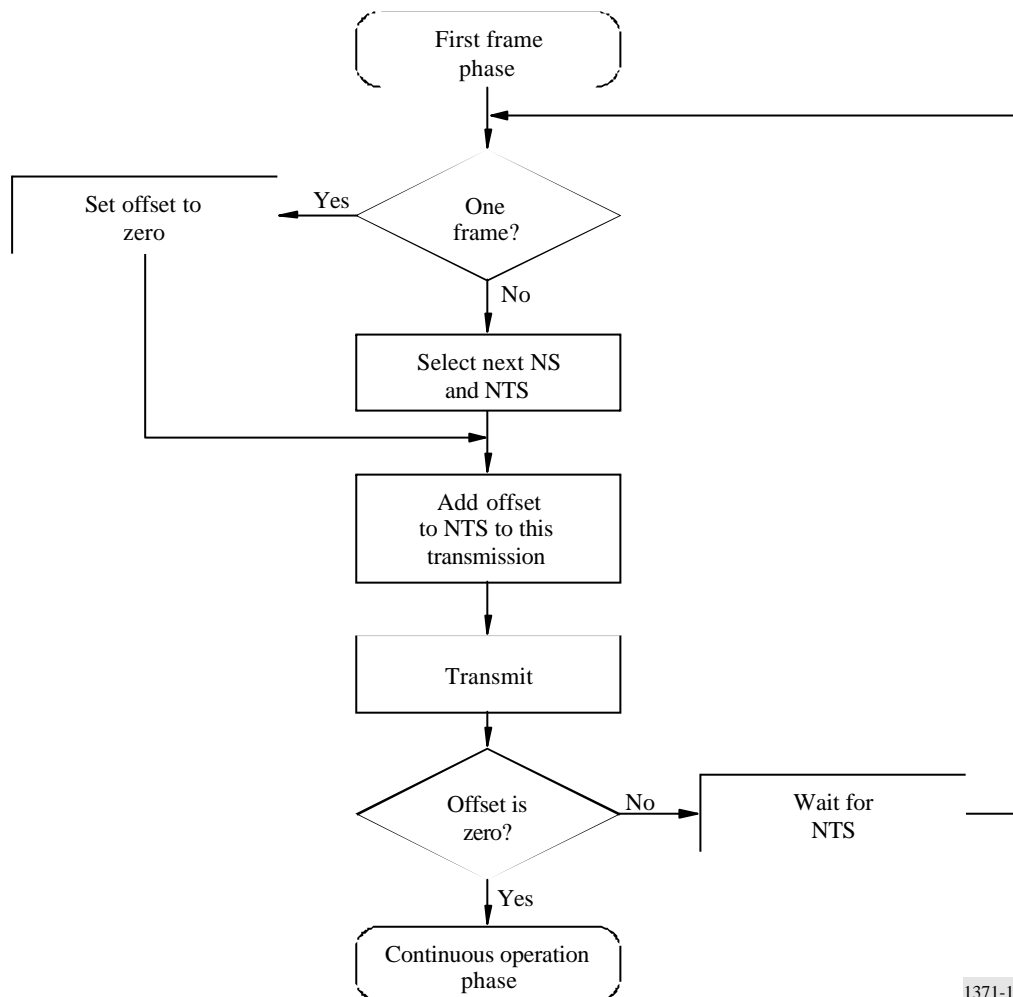

1371-12

### 2.29.2 Rationale for Clarification:

1. Editorial; inconsistency of reference within M.1371-1
2. Refer to rational of clarification of A2 § 3.3.5.1.1 Monitor VHF data link (VDL)

2.29.3 Date of amendment: 10.2001

2.29.4 Comment:

No comment

## 2.30 A2; § 3.3.5.3.1 Normal operation after one frame

### 2.30.1 Proposed Clarifying Text

*When one ~~frame~~ minute interval has elapsed, the initial transmissions should have been allocated and normal operation should commence.*

2.30.2 Rationale for Clarification:

Refer to rational of clarification of A2 § 3.3.5.1.1 Monitor VHF data link (VDL)

2.30.3 Date of amendment: 10.2001

2.30.4 Comment:

No comment

**2.31 § 3.3.5.3.2 Set offset to zero**

2.31.1 Proposed Clarifying Text

~~The offset should be used in the first frame when all transmissions use the ITDMA access scheme. The offset indicates the relative distance from the current transmission to next intended transmission. It is an incremental update of the intention of the station.~~

When all allocations have been made after one frame, the offset should be set to zero in the last transmission to indicate that no more allocations will be made.

2.31.2 Rationale for Clarification:

This section does not describe what its heading "Set offset to zero" states.

Clarification is needed.

2.31.3 Date of amendment: 10.2001

2.31.4 Comment:

No comment

**2.32 A2; § 3.3.5.3.4 Add offset to this transmission**

2.32.1 Proposed Clarifying Text

*All transmissions in the first frame phase should use the ITDMA access scheme. This structure contains an offset from the current transmission to the next slot in which a transmission is due to occur. The transmission also sets the keep flag so that receiving stations will allocate the occupied slot for one additional frame.*

2.32.2 Rationale for Clarification:

Refer to rational of clarification of A2 § 3.3.5.1.1 Monitor VHF data link (VDL)

2.32.3 Date of amendment: 10.2001

2.32.4 Comment:

No comment

**2.33 A2; § 3.3.5.4.3 Slot Time-Out is zero**

2.33.1 Proposed Clarifying Text

*If the Slot Time-Out is zero, a new NTS should be selected. The SI around the NS should be searched for candidate slots and one of the candidates should be randomly selected. The offset from the current NTS and the new NTS should be calculated and assigned as a slot offset value ( $\text{slot offset} = \text{NTS}_{\text{new}} - \text{NTS}_{\text{current}} + 2250$ ). The new NTS should be assigned a time-out value with a randomly selected value between and including TMO\_MIN and TMO\_MAX. If the Slot Time-Out is more than zero, the slot offset value should be set to zero.*

### 2.33.2 Rationale for Clarification

Clarifying slot offset value and time out value

2.33.3 Date of amendment: Edition 1.1: 12.2001

2.33.4 Comment:

## 2.34 A2; § 3.3.6 Assigned operation

### 2.34.1 Proposed Clarifying Text

If a mobile station is outside and not entering a transition zone, an autonomous station may be commanded to operate according to a specific transmission schedule, defined by a competent authority via a base ~~or repeater~~ station using Message 16, the "Assigned Mode Command". Assigned mode applies to alternating operation between both channels. When operating in the Assigned Mode, the class A shipborne mobile station should use Message 2, the "Position Report," for its transmission of all of its position reports instead of Message 1. When operating in the assigned mode the class B shipborne mobile station and the SAR aircraft station should set their assign mode flag to station operating in assigned mode The Assigned Mode should affect only the station's transmission of position reports, and no other behaviour of the station should be affected. For mobile stations other than Class A shipborne mobile stations, ~~the~~ the transmission of position reports should be only as directed by Message 16, and the station should not change its reporting rate for changing course and speed. For Class A shipborne mobile AIS stations the same rule should apply unless the autonomous mode requires a higher reporting rate than the reporting rate as directed by Message 16. If the autonomous mode requires a higher reporting rate than that directed by Message 16, the Class A shipborne mobile AIS station should use the autonomous mode. If a slot offset is given than it should be relative to the assignment transmission received. Assignments are limited in time and will be re-issued by the competent authority as needed. The last received assignment should continue or overwrite the previous assignment. This should also be the case, when two assignments are made in the same message 16 for the same station. Two levels of assignments are possible:

### 2.34.2 Rationale for Clarification:

1.) Separation of functionality of Base Station and Repeater. If a combined Base/Repeater Station is transmitting Msg. 16 then it is due to the Base Station functionality.

2.) General clarification of assigned mode needed.

2.34.3 Date of amendment: Edition 1.0: 10.2001; Edition 1.1: 12.2001

2.34.4 Comment:

Parts of this clarification have been incorporated in the design and test of Class A shipborne mobile AIS stations. Any future change to this clarification should consider not to create a legacy issue.

## 2.35 A2; § 3.3.6.2.2 Operating in the assigned mode

### 2.35.1 Proposed Clarifying Text

The assigned slots should use the SOTDMA ~~access scheme~~ CommState, with the time-out value set to the Time-Out of the assigned Slot ~~Time-Out~~. The

*assigned Slot Time-Out should be between 3 and ~~7~~ 8 frames for all assigned slots. For each frame, the Slot Time-Out should be decremented.*

2.35.2 Rationale for Clarification:

- 1) editorial.
  - 2) General clarification of assigned mode needed.
- 2.35.3 Date of amendment: Edition 1.0: 10.2001; Edition 1.1: 12.2001

2.35.4 Comment:  
No comment

**2.36 A2; § 3.3.6.2.3 Returning to autonomous and continuous mode**

2.36.1 Proposed Clarifying Text

*Unless a new assignment is received, the assignment should be terminated, when the Slot Time-Out reaches zero ~~of any assigned slot~~. At this stage, the station should return to autonomous and continuous mode.*

*The station should initiate the return to autonomous and continuous mode as soon as it detects an assigned slot with a zero Slot Time-Out. This slot should be used to re-enter the network. The station should randomly select an available slot from candidate slots within a NI of the current slot and make this the NSS. It should then substitute the assigned slot for an ITDMA slot and should use this to transmit the relative offset to the new NSS. From this point on, the process should be identical to the network entry phase (see § 3.3.5.2).*

2.36.2 Rationale for Clarification:

editorial (consequential change to clarification of assigned mode)

2.36.3 Date of amendment: 10.2001

2.36.4 Comment:  
No comment

**2.37 A2; § 3.3.7 Message structure**

2.37.1 Proposed Clarifying Text

*Messages, which are part of the access schemes, should have the following structure shown in Figure 15 inside the data portion of a data packet:*

FIGURE 15

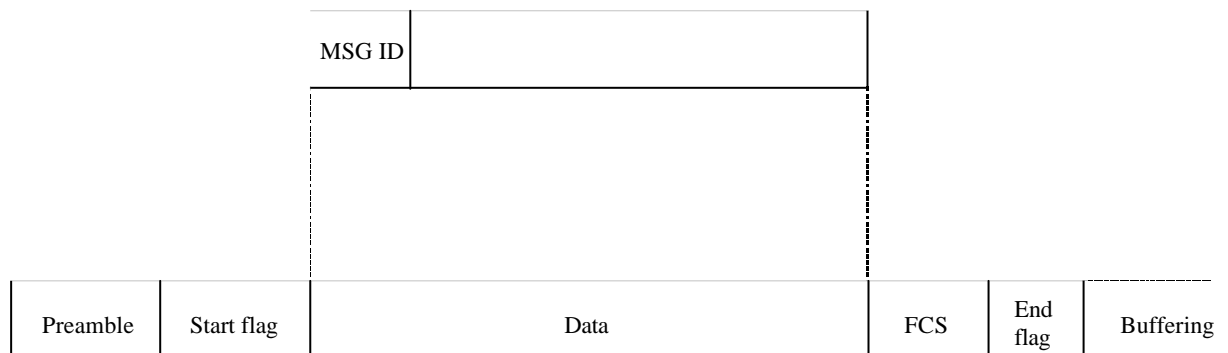

*Each message is described using a table with parameter fields listed from top to bottom. Each parameter field is defined with the most significant bit first.*

Parameter fields containing sub-fields (e.g. Communication State) are defined in separate tables with sub-fields listed top to bottom, with the most significant bit first within each sub-field.

Character strings are presented left to right most significant bit first. All unused characters should be represented by the @-symbol, and they should be placed at the end of the string.

When data is output on the VHF data link it should be grouped in bytes of 8 bits from top to bottom of the table associated with each message in accordance with ISO/IEC 3309: 1993. Each byte should be output with least significant bit first. During the output process, data should be subject to bit-stuffing (§ 3.2.2) and NRZI coding ~~as described in § 3.2.2~~ (§ 2.7).

Unused bits in the last byte should be set to zero in order to preserve byte boundary.

Generic Example for a message table:

Parameter	Symbol	No of bits	Description
P1	T	6	Parameter 1
P2	D	1	Parameter 2
P3	I	1	Parameter 3
P4	M	27	Parameter 4
P5	N	2	Parameter 5
Unused	0	3	Unused bits

Logical view of data as described in § 3.3.7:

Bit Order	M----L--	M-----	-----	-----	--LML000
Symbol	TTTTTTDI	MMMMMMMM	MMMMMMMM	MMMMMMMM	MMMN000
Byte Order	1	2	3	4	5

Output order to VHF data link (bit-stuffing is disregarded in the example):

Bit Order	--L----M	-----M	-----	-----	000LML--
Symbol	IDTTTTTT	MMMMMMMM	MMMMMMMM	MMMMMMMM	000NNMMM
Byte Order	1	2	3	4	5

### 2.37.2 Rationale for Clarification:

correct reference to M.1371-1

2.37.3 Date of amendment: Edition 1.0: 10.2001; Edition 1.3: 09.2002

2.37.4 Comment:

No comment

## 2.38 A2; §3.3.7.2.2 SOTDMA Communication State

### 2.38.1 Proposed Clarifying Text

The Communication State provides the following functions:

- 1) it contains information used by the slot allocation algorithm in the SOTDMA concept;
- 2) it also indicates the synchronization state.

The SOTDMA Communication State is structured as shown in Table 10:

TABLE 10

Parameter	Number of bits	Description
Sync state	2	0 UTC Direct (refer to § 3.1.1.1). 1 UTC Indirect (refer to § 3.1.1.2). 2 Station is synchronized to a Base station ( <u>Base direct</u> ) (refer to § 3.1.1.3). 3 Station is synchronized to another station based on the highest number of received stations <u>or to another mobile station, which is directly synchronized to a base station</u> (refer to § 3.1.1.3 and § 3.1.1.4).
Slot Time-Out	3	Specifies frames remaining until a new slot is selected. 0 means that this was the last transmission in this slot. 1-7 means that 1 to 7 frames respectively are left until slot change.
Sub message	14	The sub message depends on the current value in slot time-out as described in Table 11.

The SOTDMA Communication State should apply only to the slot in the channel where the relevant transmission occurs.

### 2.38.2 Rationale for Clarification:

It is not clear how a station can determine if another mobile is already using indirect synchronization to a base station, which does not have UTC (otherwise the status would be "UTC indirect"). This would result in more than one level of synchronization, which is prohibited. The Communication State only indicates "synchronized to base station". Therefore, there was a need to clarify the Communication State: Base Station Indirect receives Sync State value 3. No station is allowed to use this Sync State for further synchronization. The following table illustrates the different Sync Mode priorities and the contents of the Sync State fields in the Communication State.

### Illustration to rationale

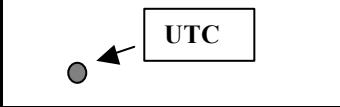
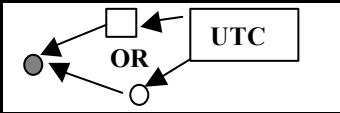
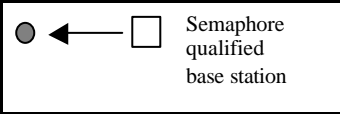
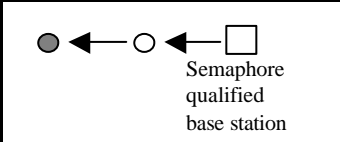
Sync Mode of Own Station	Priority	Illustration	Sync State (in CommState) of own station	May be used as source for indirect sync by other station(s)
UTC direct	1		0	Yes
UTC indirect	2		1	No
Base direct	3		2	Yes
Base indirect	4		3	No

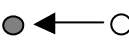
Mobile as semaphore	5	 Semaphore Qualified Mobile station	3	No
---------------------	---	---	---	----

2.38.3 Date of amendment: 10.2001

2.38.4 Comment

This clarification has been incorporated in the design and tests of Class A shipborne mobile AIS stations as far as mobile stations are affected. Any future change to this clarification should consider not to create a legacy issue.

### 2.39 A2; § 3.3.7.2.3 SOTDMA Communication State Sub Messages

2.39.1 Proposed Clarifying Text:

TABLE 11

Slot Time-Out	Sub message	Description
3, 5, 7	Received stations	Number of other stations (not own station) which the station currently is receiving (between 0 and 16383).
2, 4, 6	Slot number	Slot number used for this transmission (between 0 and 2249).
1	UTC hour and minute	If the station has access to UTC, the hour and minute should be indicated in this sub message. Hour (0-23) should be coded in bits 13 to 9 of the sub message (bit 13 is MSB). Minute (0-59) should be coded in bit 8 to 2 (bit 8 is MSB) Bit 1 and Bit b0 are not used. <u>Bit 1 and bit 0 are not used.</u>
0	Slot offset	If the Slot Time-Out value is 0 (zero) then the slot offset should indicate the <del>relative jump</del> <u>offset</u> to the slot in which transmission will occur during <u>the</u> next frame. If the slot offset is zero, the slot should be de-allocated after transmission.

2.39.2 Rationale for Clarification:

- 1.) The use of the bits for parameter UTC has been further defined
- 2.) The definition of slot offset pointing in the next frame has been clarified.

2.39.3 Date of amendment: Edition 1.1: 12.2001; Edition 1.3: 09.2002

2.39.4 Comment: editorial

### 2.40 A2; §3.3.7.3.2 ITDMA Communication State

2.40.1 Proposed Clarifying Text

*The Communication State provides the following functions:*

- 1) *it contains information used by the slot allocation algorithm in the ITDMA concept;*
- 2) *it also indicates the synchronization state.*

*The ITDMA Communication State is structured as shown in Table 12:*

TABLE 12

Parameter	Number of Bits	Description
Sync state	2	0 UTC Direct (refer to § 3.1.1.1). 1 UTC Indirect (refer to § 3.1.1.2). 2 Station is synchronized to a Base station ( <u>Base direct</u> ) (refer to § 3.1.1.3). 3 Station is synchronized to another station based on the highest Number of received stations <u>or to another mobile station, which is directly synchronized to a base station</u> (refer to § 3.1.1.3 and § 3.1.1.4).
Slot increment	13	Offset to next slot to be used, or zero (0) if no more transmissions.
Number of slots	3	Number of consecutive slots to allocate. (0 = 1 slot, 1 = 2 slots, 2 = 3 slots, 3 = 4 slots, 4 = 5 slots)
Keep flag	1	Set to TRUE (= 1) if the slot remains allocated for one additional frame (refer Table 6)

*The ITDMA Communication State should apply only to the slot in the channel where the relevant transmission occurs.*

2.40.2 Rationale for Clarification:

refer to clarification A2; § 3.3.7.2.2 SOTDMA Communication State

2.40.3 Date of amendment: 10.2001

2.40.4 Comment

This clarification has been incorporated in the design and tests of Class A shipborne mobile AIS stations as far as mobile stations are affected. Any future change to this clarification should consider not to create a legacy issue.

**2.41 A2; § 3.3.7.4.2 RATDMA message structure**

2.41.1 Proposed Clarifying Text

**3.3.7.4.2** *The Communication State when repeating a message should be set in accordance with ~~§ 4.6.2 and~~ § 4.6.3.*

2.41.2 Rationale for Clarification

Does not apply to Duplex Repeater

2.41.3 Date of amendment: Edition 1.0: 10.2001; Edition 1.3: 09.2002

2.41.4 Comment:

No comment

**2.42 A2; §3.3.7.5 FATDMA message structure**

2.42.1 Proposed Clarifying Text

*The FATDMA access scheme may use message structures determined by message ID and may thus lack a uniform structure.*

*A message with a Communication State may be transmitted using FATDMA, e.g. when repeated. In this situation, the Communication State should be set in accordance with ~~§ 4.6.2 and~~ § 4.6.3. Refer also to § A2; 3.3.8.16.*

## 2.42.2 Rationale for Clarification

Does not apply to Duplex Repeater

2.42.3 Date of amendment: Edition 1.0: 10.2001; Edition 1.3: 09.2002

2.42.4 Comment:

No comment

## 2.43 A2; § 3.3.8.1 Message summary

### 2.43.1 Proposed Clarifying Text

*The defined messages are summarized in Table 13 below.*

TABLE 13

Message ID	Name	Description	Category	Priority	Operation mode	Access Schemes	Communication State	M/B
1	Position Report	Scheduled position report; (Class A Shipborne Mobile Equipment)	F/S	1	AU	SOTDMA, RATDMA, ITDMA <sup>(1)</sup>	SOTDMA	M
2	Position Report	Assigned Scheduled position report; (Class A Shipborne Mobile Equipment)	F/S	1	AS	SOTDMA <u>(9)</u>	SOTDMA	M
3	Position Report	Special position report, response to interrogation; (Class A Shipborne Mobile Equipment)	F/S	1	AU	RATDMA <sup>(1)</sup>	ITDMA	M
4	Base Station Report	Position, UTC, Date and current Slot number of base station	F/S	1	AS <sup>(3)</sup> <sup>(7)</sup>	FATDMA RATDMA <del>ITDMA</del> <sup>(2)</sup>	SOTDMA	B
5	Static and Voyage Related Data	Scheduled static and voyage related vessel data report; (Class A Shipborne Mobile Equipment)	F	4 <sup>(5)</sup>	AU, AS	RATDMA, ITDMA <sup>(2)</sup>	N/A	M
6	Binary Addressed Message	Binary data for addressed communication	F	4	AU, AS, IN	RATDMA <u>(10)</u> , FATDMA ITDMA <sup>(2)</sup>	N/A	M/B
7	Binary Acknowledgement	Acknowledgement of received addressed binary data	S	1	AU, AS, IN	RATDMA, FATDMA ITDMA <sup>(2)</sup>	N/A	M/B
8	Binary broadcast message	Binary data for broadcast communication	F	4	AU, AS, IN	RATDMA <u>(10)</u> , FATDMA ITDMA <sup>(2)</sup>	N/A	M/B
9	Standard SAR Aircraft Position Report	Position Report for airborne stations involved in SAR operations, only	F/S	1	AU, AS	SOTDMA RATDMA, ITDMA <sup>(1)</sup>	SOTDMA, <u>ITDMA</u>	M

Technical Clarification of Rec. ITU-R M.1371-1 Edition 1.4  
December 2003

10	UTC/Date inquiry	Request UTC and date	F/S	3	AU, AS, IN	RATDMA, FATDMA ITDMA <sup>(2)</sup>	N/A	M/B
11	UTC/Date Response	Current UTC and date if available	F/S	3	AU, AS, IN	RATDMA, ITDMA <sup>(2)</sup>	SOTDMA	M
12	Addressed Safety Related Message	Safety related data for addressed communication	F	2	AU, AS, IN	RATDMA (10), FATDMA ITDMA <sup>(2)</sup>	N/A	M/B
13	Safety Related Acknowledgement	Acknowledgement of received addressed safety related message	S	1	AU, AS, IN	RATDMA, FATDMA ITDMA <sup>(2)</sup>	N/A	M/B
14	Safety Related broadcast Message	Safety related data for broadcast communication	F	2	AU, AS, IN	RATDMA (10), FATDMA ITDMA <sup>(2)</sup>	N/A	M/B
15	Interrogation	Request for a specific message type (can result in multiple responses from one or several stations) <sup>(4)</sup>	F	3	AU, AS, IN	RATDMA, FATDMA ITDMA <sup>(2)</sup>	N/A	M/B
16	Assignment Mode Command	Assignment of a specific report behaviour by competent authority using a base station	F/S	1	AS	RATDMA, FATDMA <del>ITDMA</del> <sup>(2)</sup>	N/A	B
17	DGNSS Broadcast Binary Message	DGNSS corrections provided by a base station	F	2	AS <sup>(3)</sup>	FATDMA, RATDMA, <del>ITDMA</del> <sup>(2)</sup>	N/A	B
18	Standard Class B Equipment Position Report	Standard Position Report for Class B Shipborne Mobile Equipment to be used instead of Messages 1, 2, 3 <sup>(8)</sup>	F/S	1	AU, AS	SOTDMA, ITDMA <sup>(1)</sup>	SOTDMA, ITDMA	M
19	Extended Class B Equipment Position Report	Extended Position Report for Class B Shipborne Mobile Equipment; contains additional static information <sup>(8)</sup>	F/S	1	AU, AS	ITDMA	N/A	M
20	Data Link Management Message	Reserve slots for base station(s)	S	1	AS <sup>(3)</sup>	FATDMA RATDMA, <del>ITDMA</del>	N/A	B
21	Aids-to-Navigation Report	Position and Status Report for Aids-to-Navigation	F/S	1	AU, AS, IN <sup>(3)</sup>	FATDMA, RATDMA, <del>ITDMA</del> <sup>(2)</sup>	N/A	M/B
22	Channel Management	Management of channels and transceiver modes by a base station	S	1	AS <sup>(3) (6)</sup>	FATDMA, RATDMA, <del>ITDMA</del> <sup>(2)</sup>	N/A	B

- (1) *ITDMA is used during the first frame phase (see § 3.3.5.3) and during a change of Report Rate (Rr). SOTDMA is used during the continuous operation phase (see § 3.3.5.4). RATDMA can be used at any time to transmit additional position reports.*
- (2) *This message type should be broadcast within 4 seconds. The RATDMA access scheme is the default method (see § 3.3.4.2.1) for allocating the slot(s) for this message type. Alternatively, an existing SOTDMA allocated slot ~~can~~ should, when possible, use the ITDMA access scheme for allocating the slot(s) for this message (this statement applies to mobiles only). A base station may use an existing FATDMA allocated slot for allocating the slot(s) for transmission of this message type.*
- (3) *A base station is always operating in assigned mode using a fixed transmission schedule (FATDMA) for its periodic transmissions. The "Data Link Management Message" should be used to announce the base station's fixed allocation schedule (see Message 20). If necessary, either ITDMA or RATDMA may be used to transmit non-periodic broadcasts.*
- (4) *For interrogation of UTC and date, message identifier 10 should be used.*
- (5) *Priority 3, if in response to interrogation.*
- (6) *In order to satisfy the requirements for dual channel operation (reference § 2.1.5 and § 4.1), the following should apply, unless otherwise specified by Message 22:*
  - a) *For periodic repeated messages, including the initial link access, the transmissions should alternate between AIS 1 and AIS 2.*
  - b) *Transmissions following slot allocation announcements, responses to interrogations, responses to requests, and acknowledgements should be transmitted on the same channel as the initial message.*
  - c) *For addressed messages, transmissions should utilize the channel in which a message from the addressed station was last received.*
  - d) *For non-periodic messages other than those referenced above, the transmissions of each message, regardless of message type, should alternate between AIS 1 and AIS 2.*
- (7) *Recommendations for base stations (dual channel operations): Base stations should alternate their transmissions between AIS 1 and AIS 2 for the following reasons:*
  - a) *to increase link capacity;*
  - b) *to balance channel loading between AIS 1 and AIS 2; and*
  - c) *to mitigate the harmful effects of RF interference.*
- (8) *a) Equipment other than Class B Shipborne Mobile should not transmit Messages 18 and 19.  
b) Class B Shipborne Mobile Equipment should only use Messages 18 and 19 for position reporting and static data.*
- (9) When using reporting rate assignment by Msg. 16 the Access Scheme should be SOTDMA. When using assignment of transmission slots by Msg. 16 the Access Scheme should be assigned operation (refer §3.3.2.6.2) using SOTDMA CommState.
- (10) For messages 6, 8, 12 and 14 RATDMA transmissions from a mobile station should not exceed a total of 20 slots in a frame with a maximum of 5 consecutive slots per message (see also 5.2.1).

#### 2.43.2 Rationale for Clarification:

Rationale for Clarification: Footnote (2) and ITDMA deletion as an access scheme for base stations: A base station can not use the ITDMA access scheme.

The proposal is that messages should be pre-announced by using the ITDMA channel access Communication State in an existing SOTDMA allocated slot instead of using the RATDMA channel access scheme whenever possible.

Rationale for Clarification: Footnote (9)

a) Soft impact on VDL by Msg. 16 with report rate assignment

- stations are left to their own scheduling
- A station other than the assigned one may disregard this Msg. 16
- these slots are not allocated by this base station

- b) Hard impact on the VDL by Msg. 16 with slot increment assignment
- one (own) assigned station is taken out of regular SOTDMA scheduling
  - other stations than the assigned one may disregard this Msg. 16
  - base station should be aware of the impact of this allocation

Editorial; inconsistency of reference within M.1371-1

Rationale for Clarification: Footnote (10)

To limit the use of randomly accessing the AIS VDL, which is done by the RATDMA access scheme, for long transmissions, in particular addressed messages 6, 8, 12, or 14 originated from mobiles.

2.43.3 Date of amendment: Edition 1.0: 10.2001; Edition 1.3: 09.2002; Edition 1.4: 09.2003

2.43.4 Comment:

This clarification has been incorporated in the design and tests of Class A shipborne mobile AIS stations as far as mobile stations are affected. Any future change to this clarification should consider not to create a legacy issue.

## 2.44 A2; § 3.3.8.2.1 Message 1, 2, 3: position reports

2.44.1 Proposed Clarifying Text:

*The position report should be output periodically by mobile stations.*

TABLE 15A

Parameter	Number of bits	Description
Message ID	6	Identifier for this message 1, 2 or 3
Repeat Indicator	2	Used by the repeater to indicate how many times a message has been repeated. Refer to § 4.6.1; 0 - 3; default = 0; 3 = do not repeat any more.
User ID	30	MMSI number
Navigational status	4	0 = under way using engine, 1 = at anchor, 2 = not under command, 3 = restricted manoeuvrability, 4 = Constrained by her draught; 5 = Moored; 6 = Aground; 7 = Engaged in Fishing; 8 = Under way sailing; 9 = reserved for future amendment of Navigational Status for HSC; 10 = reserved for future amendment of Navigational Status for WIG; 11 - 14 = reserved for future use; 15 = not defined = default
Rate of turn $ROT_{AIS}$	8	<p><del><math>\pm 127</math> ( <math>128</math> (80 hex) indicates not available, which should be the default). Coded by <math>ROT_{AIS} = 4.733 \text{ SQRT}(ROT_{INDICATED})</math> degrees/min</del>  <del><math>ROT_{INDICATED}</math> is the Rate of Turn (720 degrees per minute), as indicated by an external sensor.</del>  <del><math>+127</math> = turning right at 720 degrees per minute or higher;</del>  <del><math>-127</math> = turning left at 720 degrees per minute or higher</del>  <del><math>0 \dots +126</math> = turning right at up to 708 degrees per minute or higher;</del>  <del><math>0 \dots -126</math> = turning left at up to 708 degrees per minute or higher</del>                      Values between 0 and 708 degrees/min coded by  <math>ROT_{AIS} = 4.733 \text{ SQRT}(ROT_{sensor})</math> degrees/min                      where <math>ROT_{sensor}</math> is the Rate of Turn as input by an external Rate of Turn Indicator. <math>ROT_{AIS}</math> is rounded to the nearest integer value.  <del><math>+127</math> = turning right at more than <math>5^0/30s</math> (No TI available)</del>  <del><math>-127</math> = turning Left at more than <math>5^0/30s</math> (No TI available)</del>  <del><math>-128</math> (80 hex) indicates no turn information available (default).</del></p>

		<u>ROT data should not be derived from COG information.</u>
<i>SOG</i>	<i>10</i>	<i>Speed over ground in 1/10 knot steps (0-102.2 knots) 1 023 = not available, 1 022 = 102.2 knots or higher.</i>
<i>Position accuracy</i>	<i>1</i>	<i>1 = high (&lt; 10 m; Differential Mode of e.g. DGNSS receiver) 0 = low (&gt; 10 m; Autonomous Mode of e.g. GNSS receiver or of other Electronic Position Fixing Device) ; default = 0</i>
<i>Longitude</i>	<i>28</i>	<i>Longitude in 1/10 000 min (<math>\pm 180</math> degrees, East = positive (as per 2's complement), West = negative (as per 2's complement). 181 degrees (6791AC0 hex) = not available = default)</i>
<i>Latitude</i>	<i>27</i>	<i>Latitude in 1/10 000 min (<math>\pm 90</math> degrees, North = positive (as per 2's complement), South = negative (as per 2's complement). 91 degrees (3412140 hex) = not available = default)</i>
<i>COG</i>	<i>12</i>	<i>Course over ground in 1/10° (0-3599). 3600 (E10 hex) = not available = default; 3 601 – 4 095 should not be used.</i>
<i>True Heading</i>	<i>9</i>	<i>Degrees (0-359) (511 indicates not available = default).</i>
<i>Time stamp</i>	<i>6</i>	<i>UTC second when the report was generated by the EPFS (0-59, or 60 if time stamp is not available, which should also be the default value, or 62 if Electronic Position Fixing System operates in estimated (dead reckoning) mode, or 61 if positioning system is in manual input mode or 63 if the positioning system is inoperative).</i>
<i>Reserved for regional applications</i>	<i>4</i>	<i>Reserved for definition by a competent regional authority. Should be set to zero, if not used for any regional application. Regional applications should not use zero.</i>
<i>Spare</i>	<i>1</i>	<i>Not used. Should be set to zero.</i>
<i>RAIM-Flag</i>	<i>1</i>	<i>RAIM (Receiver Autonomous Integrity Monitoring) flag of Electronic Position Fixing Device; 0 = RAIM not in use = default; 1 = RAIM in use)</i>
<i>Communication State</i>	<i>19</i>	<i>See below.</i>
<i>Total number of bits</i>	<i>168</i>	

TABLE 15B

<i>Message ID</i>	<i>Communication State</i>
<i>1</i>	<i>SOTDMA Communication State as described in § 3.3.7.2.2.</i>
<i>2</i>	<i>SOTDMA Communication State as described in § 3.3.7.2.2.</i>
<i>3</i>	<i>ITDMA Communication State as described in § 3.3.7.3.2.</i>

#### 2.44.2 Rationale for Clarification:

- 1.) ROT<sub>indicated</sub> has been replaced by ROT<sub>sensor</sub> to improve clarity as this information is input to the AIS from the external sensor  
There was a misinterpretation possible to wrongly interpret the MSB as a North/South or East/West-Flag
- 2.) The fallback arrangement to derive turn information from heading as in IEC AIS Class A test standard is reflected

3.) Prohibition to use COG for ROT indicator

4.) The rounding of ROT<sub>AIS</sub> has been clarified.

2.44.3 Date of amendment: Edition 1.0 10.2001; Edition 1.1: 12.2001

2.44.4 Comment:

This clarification has been incorporated in the design and tests of Class A shipborne mobile AIS stations as far as mobile stations are affected. Any future change to this clarification should consider not to create a legacy issue.

## 2.45 A2; §3.3.8.2.2 Message 4: Base station report Message 11: UTC and date response

### 2.45.1 Proposed Clarifying Text

*Should be used for reporting UTC time and date and, at the same time, position. A base station should use Message 4 in its periodical transmissions. A mobile station should output Message 11 only in response to interrogation by Message 10.*

*Message 11 is only transmitted as a result of a UTC Request message (Message 10). The UTC and Date response should be transmitted on the channel, where the UTC request message was received.*

TABLE 16

Parameter	Number of bits	Description
Message ID	6	Identifier for this message 4, 11 4 = UTC and position report from base station; 11 = UTC and position response from mobile station.
Repeat Indicator	2	Used by the repeater to indicate how many times a message has been repeated. Refer to § 4.6.1; 0 - 3; default = 0; 3 = do not repeat any more.
User ID	30	MMSI number
UTC year	14	1 - 9999; 0 = UTC year not available = default.
UTC month	4	1 - 12; 0 = UTC month not available = default; 13 - 15 not used
UTC day	5	1 - 31; 0 = UTC day not available = default.
UTC hour	5	0 - 23; 24 = UTC hour not available = default; 25 - 31 not used
UTC minute	6	0 - 59; 60 = UTC minute not available = default; 61 - 63 not used
UTC second	6	0 - 59; 60 = UTC second not available = default; 61 - 63 not used.
Position accuracy	1	1 = high (< 10 m; Differential Mode of e.g. DGNSS receiver) 0 = low (> 10 m; Autonomous Mode of e.g. GNSS receiver, or of other Electronic Position Fixing Device), default = 0
Longitude	28	Longitude in 1/10 000 minute ( $\pm 180$ degrees, East = positive (as per 2's complement), West = negative (as per 2's complement); 181 degrees (6791AC0 hex) = not available = default)

<i>Latitude</i>	27	<i>Latitude in 1/10 000 minute (<math>\pm 90</math> degrees, North = positive (as per 2's complement), South = negative (as per 2's complement); 91 degrees (3412140 hex) = not available = default)</i>
<i>Type of Electronic Position Fixing Device</i>	4	<i>Use of differential corrections is defined by field "position accuracy" above; 0 = Undefined (default), 1 = GPS, 2 = GLONASS, 3 = Combined GPS/GLONASS, 4 = Loran-C, 5 = Chayka, 6 = Integrated Navigation System, 7 = surveyed, 8 - 15 = not used.</i>
<i>Spare</i>	10	<i>Not used. Should be set to zero.</i>
<i>RAIM-Flag</i>	1	<i>RAIM (Receiver Autonomous Integrity Monitoring) flag of Electronic Position Fixing Device; 0 = RAIM not in use = default; 1 = RAIM in use)</i>
<i>Communication State</i>	19	<i>SOTDMA Communication State as described in § 3.3.7.2.2.</i>
<i>Total number of bits</i>	168	

**2.45.2 Rationale for Clarification:**

There was a misinterpretation possible to wrongly interpret the MSB as a North/South or East/West-Flag.

**2.45.3 Date of amendment:** 10.2001

**2.45.4 Comment:**

No comment

**2.46 A2; § 3.3.8.2.3 Message 5: Ship Static and Voyage related data**

**2.46.1 Proposed Clarifying Text**

*Should only be used by Class A Shipborne Mobile Equipment when reporting static or voyage related data.*

TABLE 17

<i>Parameter</i>	<i>Number of bits</i>	<i>Description</i>
<i>Message ID</i>	6	<i>Identifier for this message 5</i>
<i>Repeat Indicator</i>	2	<i>Used by the repeater to indicate how many times a message has been repeated. Refer to § 4.6.1; 0 - 3; default = 0; 3 = do not repeat any more.</i>
<i>User ID</i>	30	<i>MMSI number</i>
<i>AIS Version Indicator</i>	2	<i>0 = Station compliant with AIS Edition 0; 1 - 3 = Station compliant with future AIS Editions 1, 2, and 3.</i>
<i>IMO number</i>	30	<i>1 - 999999999; 0 = not available = default</i>

Call sign	42	7 ~ 6 bit ASCII characters, "@@@@@@@" = not available = default.
Name	120	Maximum 20 characters 6 bit ASCII, "@@@@@@@@@@@@@@@@@@" = not available = default.
Type of ship and cargo type	8	0 = not available or no ship = default; 1 - 99 = as defined in § 3.3.8.2.3.2; 100 - 199 = preserved, for regional use; 200 - 255 = preserved, for future use.
<u>Overall</u> Dimension/Reference for Position	30	Reference point for reported position; Also indicates the dimension of ship in metres (see Fig. 18 and § 3.3.8.2.3.3)
Type of Electronic Position Fixing Device	4	0 = Undefined (default); 1 = GPS, 2 = GLONASS, 3 = Combined GPS/GLONASS, 4 = Loran-C, 5 = Chayka, 6 = Integrated Navigation System, 7 = surveyed, 8 - 15 = not used.
ETA	20	Estimated Time of Arrival; MMDDHHMM UTC
		Bits 19 - 16: month; 1 - 12; 0 = not available = default;
		Bits 15 - 11: day; 1 - 31; 0 = not available = default;
		Bits 10 - 6: hour; 0 - 23; 24 = not available = default;
		Bits 5 - 0: minute; 0 - 59; 60 = not available = default
Maximum Present Static Draught	8	in 1/10 m, 255 = draught 25.5 m or greater, 0 = not available = default; in accordance with IMO Resolution A.851
Destination	120	Maximum 20 characters using 6-bit ASCII; "@@@@@@@@@@@@@@@@@@" = not available.
DTE	1	Data terminal ready (0 = available, 1 = not available = default)
Spare	1	Spare. Not used. Should be set to zero.
Number of bits	424	Occupies 2 slots

*This message should be transmitted immediately after any parameter value has been changed.*

**2.46.2 Rationale for Clarification:**

This clarification removes ambiguity to what dimensions to use for this field (overall dimension).

**2.46.3 Date of amendment: 10.2001**

**2.46.4 Comment:**

No comment

**2.47 A2; § 3.3.8.2.3.3 Reference Point for reported position and Dimensions of Ship**

2.47.1 Proposed Clarifying Text

**§ 3.3.8.2.3.3 Reference Point for reported position and overall Dimensions of Ship**

FIGURE 18

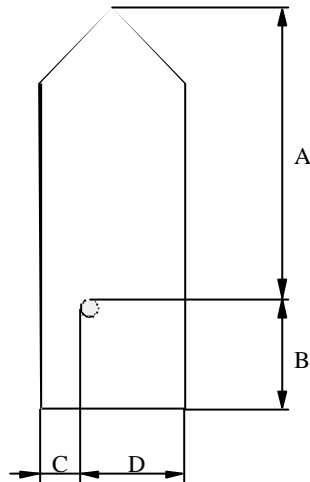

	Number of Bits	Bit fields	Distance (m)
A	9	<del>Bit 0 – Bit 8</del> Bit 21 – Bit 29	0 – 511 511=511m or greater
B	9	Bit 9 – Bit 17 Bit 12 – Bit 20	0 – 511 511=511m or greater
C	6	Bit 18 – Bit 23 Bit 6 – Bit 11	0 - 63 ; 63 = 63 m or greater
D	6	<del>Bit 24 – Bit 29</del> Bit 0 – Bit 5	0 - 63 ; 63 = 63 m or greater

The dimension A should be in the direction of the transmitted heading information (bow)

Reference point of reported position not available, but dimensions of ship are available:  $A = C = 0$  and  $B \neq 0$  and  $D \neq 0$ .

Neither reference point of reported position nor dimensions of ship available:  $A = B = C = D = 0$  (=default)

For use in the message table, A = most significant field, D = least significant field

2.47.2 Rationale / Reason for Clarification:

This clarification removes ambiguity what dimensions to use for this field.

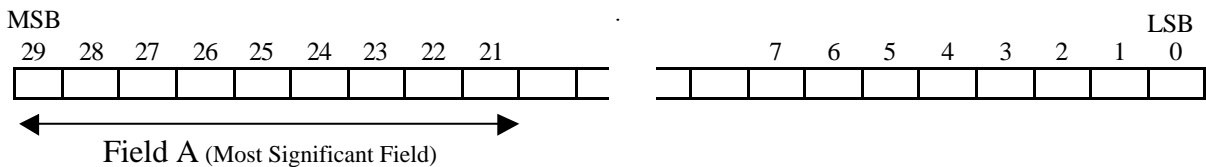

2.47.3 Date of amendment: Edition 1.0: 10.2001; Edition 1.3: 07.2002

2.47.4 Comment:

This clarification has been incorporated in the design and tests of Class A shipborne mobile AIS stations as far as mobile stations are affected. Any future change to this clarification should consider not to create a legacy issue.

**2.48 A2; § 3.3.8.2.4 Message 6: Addressed Binary Message**

2.48.1 Proposed Clarifying Text

The Addressed Binary Message should be variable in length, based on the amount of binary data. The length should vary between 1 and 5 slots. See Application Identifiers in § 3.3.8.2.4.1.

TABLE 19

<i>Parameter</i>	<i>Number of bits</i>	<i>Description</i>		
<i>Message ID</i>	<i>6</i>	<i>Identifier for Message 6; always 6</i>		
<i>Repeat Indicator</i>	<i>2</i>	<i>Used by the repeater to indicate how many times a message has been repeated. Refer to § 4.6.1; 0 - 3; default = 0; 3 = do not repeat any more.</i>		
<i>Source ID</i>	<i>30</i>	<i>MMSI number of source station</i>		
<i>Sequence Number</i>	<i>2</i>	<i>0 - 3; refer to § 5.3.1</i>		
<i>Destination ID</i>	<i>30</i>	<i>MMSI number of destination station</i>		
<i>Retransmit Flag</i>	<i>1</i>	<i>Retransmit Flag should be set upon retransmission: 0 = no retransmission = default; 1 = retransmitted.</i>		
<i>Spare</i>	<i>1</i>	<i>Not used. Should be zero</i>		
<i>Binary Data</i>	<i>Max 936</i>	<i>Application Identifier</i>	<i>16 bits</i>	<i>Should be as described in § 3.3.8.2.4.1</i>
		<i>Application Data</i>	<i>Max 920 bits</i>	<i>Application specific data</i>
<i>Maximum Number of bits</i>	<i>Max 1 008</i>	<i>Occupies 1 to 5 slots subject to the length of sub-field Message Content</i> <u><i>[For Class B mobile AIS stations the length of the message should not exceed 2 slots]</i></u>		

*Additional bit stuffing will be required for these message types. For details refer to Transport Layer, § 5.2.1.*

*The following table gives the number of binary data bytes (including Application ID and Application Data), so that the whole message fits into a given number of slots. It is recommended that any application minimizes the use of slots by limiting the number of binary data bytes to the numbers given, if possible:*

<i>Number of slots</i>	<i>Maximum binary data bytes</i>
<i>1</i>	<i>8</i>
<i>2</i>	<i>36</i>
<i>3</i>	<i>64</i>
<i>4</i>	<i>92</i>
<i>5</i>	<i>117</i>

*These numbers also take bit stuffing into account.*

**2.48.2 Rationale / Reason for Clarification:**

[Prevents high channel load on the VDL caused by long transmission packets from Class B units.]

2.48.3 Date of amendment: Edition 1.4: 09.2003

2.48.4 Comment:

No comment

**2.49 A2; § 3.3.8.2.6 Message 8: Binary Broadcast Message**

**2.49.1 Proposed Clarifying Text**

*This message will be variable in length, based on the amount of binary data. The length should vary between 1 and 5 slots.*

TABLE 22

<i>Parameter</i>	<i>Number of bits</i>	<i>Description</i>		
<i>Message ID</i>	<i>6</i>	<i>Identifier for message 8; always 8</i>		
<i>Repeat Indicator</i>	<i>2</i>	<i>Used by the repeater to indicate how many times a message has been repeated. Refer to § 3.3.8.2.1.1.</i>		
<i>Source ID</i>	<i>30</i>	<i>MMSI number of source station</i>		
<i>Spare</i>	<i>2</i>	<i>Not used. Should be set to zero</i>		
<i>Binary Data</i>	<i>Max 968</i>	<i>Application Identifier</i>	<i>16 bits</i>	<i>Should be as described in § 3.3.8.2.4.1</i>
		<i>Application Data</i>	<i>Max 952 bits</i>	<i>Application specific data</i>
<i>Total Number of bits</i>	<i>Max 1008</i>	<i>Occupies 1 to 5 slots</i> <u><i>[For Class B mobile AIS stations the length of the message should not exceed 2 slots.]</i></u>		

*The following table gives the number of binary data bytes (including Application ID and Application Data), so that the whole message fits into a given number of slots. It is recommended that any application minimizes the use of slots by limiting the number of binary data bytes to the numbers given, if possible:*

<i>Number of slots</i>	<i>Maximum binary data bytes</i>
<i>1</i>	<i>12</i>
<i>2</i>	<i>40</i>
<i>3</i>	<i>68</i>
<i>4</i>	<i>96</i>
<i>5</i>	<i>121</i>

*These numbers also take into account bit stuffing.*

*Additional bit stuffing will be required for this message type. For details refer to Transport Layer, § 5.2.1.*

**2.49.2 Rationale / Reason for Clarification:**

[Prevents high channel load on the VDL caused by long transmission packets from Class B units.]

2.49.3 Date of amendment: Edition 1.4: 09.2003

2.49.4 Comment:

No comment

**2.50 A2; § 3.3.8.2.7 Message 9: Standard SAR Aircraft Position Report**

**2.50.1 Proposed Clarifying Text**

*This message should be used as a standard position report for aircraft involved in SAR operations instead of Messages 1, 2 or 3. Stations other than aircraft involved in SAR operations should not use transmit this message. The default reporting interval for this message should be 10 seconds.*

TABLE 23

Parameter	Number of bits	Description
Message ID	6	Identifier for message 9; always 9
Repeat Indicator	2	Used by the repeater to indicate how many times a message has been repeated. Refer to § 4.6.1; 0 - 3; default = 0; 3 = do not repeat any more.
User ID	30	MMSI number
Altitude (GNSS)	12	Altitude (derived from GNSS) expressed in metres (0 – 4 094 metres) 4 095 = not available, 4 094 = 4 094 metres or higher
SOG	10	Speed over ground in knot steps (0-1 022 knots) 1 023 = not available, 1 022 = 1 022 knots or higher
Position accuracy	1	1 = high (< 10 m; Differential Mode of e.g. DGNSS receiver) 0 = low (> 10 m; Autonomous Mode of e.g. GNSS receiver or of other Electronic Position Fixing Device) ; default = 0
Longitude	28	Longitude in 1/10 000 min ( $\pm 180$ degrees, East = positive (as per 2's complement), West = negative (as per 2's complement). 181 degrees (6791AC0 hex) = not available = default)
Latitude	27	Latitude in 1/10 000 min ( $\pm 90$ degrees, North = positive (as per 2's complement), South = negative (as per 2's complement). 91 degrees (3412140 hex) = not available = default)
COG	12	Course over ground in 1/10° (0-3599). 3600 (E10 hex) = not available = default; 3 601 - 4 095 should not be used.
Time stamp	6	UTC second when the report was generated by the EPFS (0-59, or 60 if time stamp is not available, which should also be the default value, or 62 if Electronic Position Fixing System operates in estimated (dead reckoning) mode, or 61 if positioning system is in manual input mode or 63 if the positioning system is inoperative)
Reserved for regional applications	8	Reserved for definition by a competent regional authority. Should be set to zero, if not used for any regional application. Regional applications should not use zero.
DTE	1	Data terminal ready (0 = available 1 = not available = default) (refer to § 3.3.8.2.3.1).
Spare	<del>5</del> 3	Not used. Should be set to zero
Assigned Mode Flag	1	0 = Station operating in autonomous and continuous mode = default 1 = Station operating in assigned mode
RAIM-Flag	1	RAIM (Receiver Autonomous Integrity Monitoring) flag of Electronic Position Fixing Device; 0 = RAIM not in use = default; 1 = RAIM in use)
Communication State Selector Flag	1	0 = SOTDMA Communication State follows; 1 = ITDMA Communication State follows.
Communication State	19	SOTDMA (refer to § 3.3.7.2.2).
Total number of bits	168	

**2.50.2 Rationale / Reason for Clarification:**

1.) There was a misinterpretation possible to wrongly interpret the MSB as a North/South or East/West-Flag.

Without the Communication Selector State Flag SAR can only use SOTDMA Communication State.

It is not normal to use SOTDMA to access the link. This abnormal behavior requires a special algorithm to work. Also it causes unwanted random behavior on the VHF Data Link when starting up or changing reporting rates (entering or leaving assigned mode).

The normal way is to use a RATDMA message with ITDMA Communication State. The SAR Airborne mobile AIS station will, after this change, have identical behavior as the Class B shipborne mobile AIS station.

2.) Introduction of Assignment Mode Flag in order to indicate which SAR Airborne mobile AIS station has entered assigned mode.

2.50.3 Date of amendment: 10.2001

2.50.4 Comment:

No comment

**2.51 A2; § 3.3.8.2.8 Message 10: UTC and Date Inquiry**

**2.51.1 Proposed Clarifying Text**

*This message should be used when a station is requesting UTC and date from another station. [The inquiry for UTC and Date should be addressed to units with UTC direct only.]*

TABLE 24

<i>Parameter</i>	<i>Number of bits</i>	<i>Description</i>
<i>Message ID</i>	6	<i>Identifier for message 10; always 10</i>
<i>Repeat Indicator</i>	2	<i>Used by the repeater to indicate how many times a message has been repeated. Refer to § 4.6.1; 0 - 3; default = 0; 3 = do not repeat any more.</i>
<i>Source ID</i>	30	<i>MMSI number of station which inquires UTC</i>
<i>Spare</i>	2	<i>Not used. Should be set to zero.</i>
<i>Destination ID</i>	30	<i>MMSI number of station which is inquired</i>
<i>Spare</i>	2	<i>Not used. Should be set to zero.</i>
<i>Total number of bits</i>	72	

*For Message 11 refer to description of Message 4.*

**2.51.2 Rationale / Reason for Clarification:**

[AIS stations without UTC direct could transmit erroneous data.]

2.51.3 Date of amendment: Edition 1.4: 09.2003

2.51.4 Comment:

No comment

## 2.52 A2; § 3.3.8.2.9 Message 12: Addressed Safety Related Message

### 2.52.1 Proposed Clarifying Text

*The Addressed Safety Related Message could be variable in length, based on the amount of safety related text. The length should vary between 1 and 5 slots.*

TABLE 25

Parameter	Number of bits	Description
Message ID	6	Identifier for Message 12; always 12
Repeat Indicator	2	Used by the repeater to indicate how many times a message has been repeated. Refer to § 4.6.1; 0 - 3; default = 0; 3 = do not repeat any more.
Source ID	30	MMSI number of station which is the source of the message
Sequence Number	2	0 - 3; refer to § 5.3.1.
Destination ID	30	MMSI number of station which is the destination of the message
Retransmit Flag	1	Retransmit Flag should be set upon retransmission: 0 = no retransmission = default; 1 = retransmitted.
Spare	1	Not used. Should be zero.
Safety related text	Max 936	6-bit ASCII.
Total Maximum Number of bits	Max 1 008	Occupies 1 to 5 slots subject to the length of text <u>For Class B mobile AIS stations the length of the message should not exceed 2 slots.</u>

*Additional bit stuffing will be required for this message type. For details refer to Transport Layer, § 5.2.1.*

*The following table gives the number of 6-bit-ASCII characters, so that the whole message fits into a given number of slots. It is recommended that any application minimizes the use of slots by limiting the number of characters to the numbers given, if possible:*

Number of slots	Maximum 6-bit ASCII characters
1	10
2	48
3	85
4	122
5	156

*These numbers also take bit stuffing into account.  
For Message 13 refer to description of Message 7.*

### 2.52.2 Rationale / Reason for Clarification:

Prevents high channel load on the VDL caused by long transmission packets from Class B units.

2.52.3 Date of amendment: Edition 1.4: 09.2003

2.52.4 Comment:

No comment

## 2.53 A2; § 3.3.8.2.10 Message 14: Safety Related broadcast Message

### 2.53.1 Proposed Clarifying Text

*The Safety Related Broadcast Message could be variable in length, based on the amount of safety related text. The length should vary between 1 and 5 slots.*

TABLE 26

Parameter	Number of bits	Description
Message ID	6	Identifier for message 14; always 14.
Repeat Indicator	2	Used by the repeater to indicate how many times a message has been repeated. Refer to § 4.6.1; 0 - 3; default = 0; 3 = do not repeat any more.
Source ID	30	MMSI number of source station of message
Spare	2	Not used. Should be set to zero.
Safety related Text	Max 968	6-bit ASCII.
Total Number of bits	Max 1 008	Occupies 1 to 5 slots subject to the length of text <u>For Class B mobile AIS stations the length of the message should not exceed 2 slots</u>

*Additional bit stuffing will be required for this message type. For details refer to Transport Layer, § 5.2.1.*

*The following table gives the number of 6-bit ASCII characters, so that the whole message fits into a given number of slots. It is recommended that any application minimizes the use of slots by limiting the number of characters to the numbers given, if possible:*

Number of slots	Maximum 6-bit ASCII characters
1	16
2	53
3	90
4	128
5	161

*These numbers also take bit stuffing into account.*

### 2.53.2 Rationale / Reason for Clarification:

[Prevents high channel load on the VDL caused by long transmission packets from Class B units.]

2.53.3 Date of amendment: Edition 1.4: 09.2003

2.53.4 Comment:

No comment

**2.54 A2; § 3.3.8.2.11 Message 15 Interrogation**

2.54.1 Proposed Clarifying Text

~~This Interrogation Message should be used for interrogations via the TDMA (not DSC) VHF TDMA data link other than requests for UTC and date requests. The response should be transmitted on the channel where the interrogation was received.~~

*A Class A Shipborne Mobile Station can be interrogated for message identifiers 3 and 5, by another station. A Class B Shipborne Mobile Station can be interrogated for message identifiers 18 and 19, by another station. An airborne mobile station can be interrogated for message identifier 9, by another station. A mobile station mounted on an Aids-to-Navigation can be interrogated for message identifier 21, by another station. A base station can be interrogated for message identifiers 4, 17, 20 and 22.*

<u>Interrogator</u>	<u>Class A</u>	<u>Class B</u>	<u>SAR aircraft</u>	<u>AtoN</u>	<u>Base Station</u>
<u>Interrogated</u>					
<u>Class A</u>	<u>C: 3, 5</u>	<u>N ?</u>	<u>C: 3, 5</u>	<u>O: 3, 5</u>	<u>C: 3, 5</u>
<u>Class B</u>	<u>C: 18, 19</u>	<u>C: 18, 19</u>	<u>C: 18, 19</u>	<u>O: 18, 19</u>	<u>C: 18, 19</u>
<u>SAR-aircraft</u>	<u>C: 9</u>	<u>C: 9</u>	<u>C: 9</u>	<u>O: 9</u>	<u>C: 9</u>
<u>AtoN</u>	<u>C: 21</u>	<u>C: 21</u>	<u>C: 21</u>	<u>O: 21</u>	<u>C: 21</u>
<u>Base Station</u>	<u>C: 4, 17, 20, 22</u>	<u>C: 4, 17, 20, 22</u>	<u>C: 4, 17, 20, 22</u>	<u>O: 4, 17, 20, 22</u>	<u>C: 4, 17, 20, 22</u>

*The parameter "Slot Offset" should be set to zero, if slot should autonomously be allocated by the responding station. An interrogating mobile station should always set the parameter 'Slot Offset' to zero. Slot assignments for the reply to an interrogation should only be used by a base station. If a "Slot Offset" is given, it should be relative to the start slot of this transmission. There should be the following four (4) possibilities to use this message:*

- 1) *One (1) station is interrogated one (1) message: The parameters Destination ID1, Message ID1.1 and Slot Offset 1.1 should be defined. All other parameters should be omitted.*
- 2) *One (1) station is interrogated two (2) messages: The parameters Destination ID1, Message ID1.1, Slot Offset 1.1, Message ID1.2, and Slot Offset 1.2 should be defined. The parameters Destination ID2, Message ID2.1, and Slot Offset 2.1 should be omitted. Refer to § 3.3.7 for byte boundaries.*
- 3) *The first station and the second station are interrogated one (1) message each: The parameters Destination ID1, Message ID1.1, Slot Offset 1.1, Destination ID2, Message ID2.1, and Slot Offset 2.1 should be defined. The parameters Message ID1.2 and Slot Offset 1.2 should be set to zero (0).*
- 4) *The first station is interrogated two (2) messages, and the second station is interrogated one (1) message: All parameters should be defined.*

**TABLE 27**

<i>Parameter</i>	<i>Number of bits</i>	<i>Description</i>
<i>Message ID</i>	6	<i>Identifier for message 15; always set to 15</i>

<i>Repeat Indicator</i>	2	<i>Used by the repeater to indicate how many times a message has been repeated. Refer to § 4.6.1; 0 - 3; default = 0; 3 = do not repeat any more.</i>
<i>Source ID</i>	30	<i>MMSI number of interrogating station</i>
<i>Spare</i>	2	<i>Not used. Should be set to zero</i>
<i>Destination ID1</i>	30	<i>MMSI number of first interrogated station</i>
<i>Message ID1.1</i>	6	<i>First Requested message type from first interrogated station</i>
<i>Slot offset 1.1</i>	12	<i>Response slot offset for first requested message from first interrogated station</i>
<i>Spare</i>	2	<i>Not used. Should be set to zero</i>
<i>Message ID1.2</i>	6	<i>Second Requested message type from first interrogated station.</i>
<i>Slot offset 1.2</i>	12	<i>Response slot offset for second requested message from first interrogated station</i>
<i>Spare</i>	2	<i>Not used. Should be set to zero</i>
<i>Destination ID 2</i>	30	<i>MMSI number of second interrogated station</i>
<i>Message ID 2.1</i>	6	<i>Requested message type from second interrogated station.</i>
<i>Slot offset 2.1</i>	12	<i>Response slot offset for requested message from second interrogated station.</i>
<i>Spare</i>	2	<i>Not used. Should be set to zero</i>
<i>Total number of bits</i>	88-160	<i>Total number of bits depends upon number of messages requested.</i>

#### 2.54.2 Rationale for Clarification

- 1.) A clarification was needed to what station should be able to interrogate what other station for what kind of message.
- 2.) Slot assignments ("hard") should be reserved for base stations in order to have only one consistent assignment scheme in a given area. This single consistent assignment scheme should be provided by the competent authority. This is due to the sensitivity of slot assignments. Mobiles performing slot assignment beyond control of the base station and outside of this consistent assignment scheme could disrupt the AIS VDL. Therefore, mobiles should not use slot assignments when interrogating, regardless of their class.

2.54.3 Date of amendment: Edition 1.0: 10.2001; Edition 1.1: 12.2001; Edition 1.3: 09.2002

#### 2.54.4 Comment:

This clarification has been incorporated in the design and tests of Class A shipborne mobile AIS stations as far as mobile stations are affected. Any future change to this clarification should consider not to create a legacy issue.

### 2.55 A2; § 3.3.8.2.12 Message 16: Assigned Mode Command

#### 2.55.1 Proposed Clarifying Text

*Assignment should be transmitted by a base station when operating as a controlling entity. Other stations can be assigned a transmission schedule,*

*other than the currently used one. If a station is assigned a schedule, it will also enter assigned mode.*

*Two stations can be assigned simultaneously.*

*When receiving an assignment schedule, the station should tag it with a time-out, randomly selected between 4 and 8 minutes after the first transmission.*

*When a Class A shipborne mobile AIS station receives an assignment it should revert to either the assigned reporting rate or the resulting reporting rate (when slot assignment is used) or the autonomously derived reporting rate (refer to 4.3.1), whatever is higher. The Class A shipborne mobile AIS station should indicate that it is in assigned mode (by using the appropriate messages), even if it reverts to a higher autonomously derived reporting rate.*

*NOTE – A base station should monitor the mobile station's transmissions in order to determine when the mobile station will time-out.*

*For bounds of assignment settings refer to Table 9.*

*Transmissions of Msg. 16 by base stations using assignment of transmission slots should consider directing transmissions to slots which have previously been reserved by the base station by FATDMA (Msg. 20).*

*If continued assignment is required, the new assignment should be transmitted before the start of the last frame of the previous assignment.*

TABLE 28

Parameter	Number of bits	Description
Message ID	6	Identifier for message 16. Always 16
Repeat Indicator	2	Used by the repeater to indicate how many times a message has been repeated. Refer to § 4.6.1; 0 - 3; default = 0; 3 = do not repeat any more.
Source ID	30	MMSI of assigning station.
Spare	2	Spare. Should be set to zero.
Destination ID A	30	MMSI Number. Destination identifier A.
Offset A	12	Offset from current slot to first assigned slot <sup>(1)</sup> .
Increment A	10	Increment to next assigned slot. <sup>(1)</sup>
Destination ID B	30	MMSI Number. Destination identifier B. Should be omitted if there is assignment to station A, only.
Offset B	12	Offset from current slot to first assigned slot. Should be omitted if there is assignment to station A, only <sup>(1)</sup> .
Increment B	10	Increment to next assigned slot <sup>(1)</sup> . Should be omitted, if there is assignment to station A, only.
Spare	Max 4	Spare. Not used. Should be set to zero. The number of spare bits, which should be 0 or 4, should be adjusted in order to observe byte boundaries.
Total	96 or 144	Should be 96 or 144 bits.

<sup>(1)</sup> ~~To assign a reporting rate for a station, the parameter "Increment" should be set to zero. In order to facilitate low reporting rates, the~~ The parameter "Offset" should then be interpreted as the number of reports in a time interval of 10 minutes.

~~The base station making the assignment to the mobile station should consider the time-out behaviour of the mobile station when assigning this value.~~

When number of reports per 10 minutes are assigned only multiples of 20 between 20 and 600 should be used. If a mobile station received a value which is not a multiple of 20 but below 600 it should use the next higher multiple of 20. If a mobile station receives a value greater than 600 it should use 600.

When slot increments are assigned, one of the following increment parameter settings should be used:

0 = see above;

1 = 1125 slots

2 = 375 slots

3 = 225 slots

4 = 125 slots

5 = 75 slots

6 = 45 slots, and

7 = undefined.

If a station receives the value 7, the station should disregard this assignment."

[Class B mobile AIS stations should not be assigned a reporting interval less than [2] seconds.]

### 2.55.2 Rationale for Clarification

The M.1371-1 provides two kind of assignment: Assignment of a certain reporting rate. This allows the mobile now working in "assigned mode" to select the necessary slots autonomously by using the standard access scheme(s) for autonomously allocating slots. Therefore, the impact on the AIS VDL is to be considered "soft". M.1371-1 also provides the possibility to assign slots. This may be beneficial in e. g. situations, where a base station wishes to protect the transmission of a particular mobile by assigning slots, which have been pre-allocated by the base station by FATDMA and which may not be used by other mobiles. Therefore slot assignment may be considered a "hard" assignment mechanism. As a consequence of the sophistication of the access schemes of the AIS and the dual-channel operation, there are only possible certain values to assign. These values can be calculated, and they are given - in the case of slot assignment ("hard") – in the clarification above. The "soft" assignment *directly* assigns a certain reporting rate, whereas "hard" assignment will create a *resulting* reporting rate, as the number of actually transmitted, slot-allocated position reports of a mobile station may be divided by a time period, e. g. a minute interval, thus translating into a resulting reporting rate.

The slot-assignment value of 25 would lead to an assigned resulting update rate of more than one per second. This would create ambiguities for the recipient of position reports due to a resolution of the time stamp of one full UTC second, only.

In order to guarantee that a mobile station reverts to a defined mode of assigned operation even if it receives slot offset numbers different from the ones given above, a uniform algorithm to revert to a defined number should be used in all mobile stations. This could be done simplest by encoding defined values of slot offset in the increment parameter itself (see above).

From an operational point of view the reporting rates (resulting reporting rates at slot assignment) of Class A shipborne mobile AIS devices should not drop below the autonomously derived reporting rates as stated in Table 1A of Annex 1 of M.1371-1, not even in assigned mode operation. This requirement leads to the initiation of two processes simultaneously, whenever a Class A shipborne mobile AIS station receives an assignment command (refer to rational of clarification of A1; § 4.2.1).

[Class B units are not required to operate at a rate higher than needed to support semaphore synchronization.]

2.55.3 Date of amendment: 10.2001; Edition 1.4:09.2003

2.55.4 Comment:

This clarification has been incorporated in the design and tests of Class A shipborne mobile AIS stations as far as mobile stations are affected. Any future change to this clarification should consider not to create a legacy issue.

## 2.56 A2; 3.3.8.2.14 Message 18: Standard Class B Equipment Position Report

### 2.56.1 Proposed Clarifying Text

*The Standard Class B Equipment Position Report should be output periodically and autonomously instead of Messages 1, 2, or 3 by Class B Shipborne Mobile Equipment, only. The reporting interval should default to the values given in Table 1B, unless otherwise specified by the competent*

authority, depending on the current SOG, the current Navigational status flag setting.

TABLE 31

Parameter	Number of bits	Description
Message ID	6	Identifier for message 18; always 18
Repeat Indicator	2	Used by the repeater to indicate how many times a message has been repeated. Refer to § 4.6.1; 0 - 3; default = 0; 3 = do not repeat any more.
User ID	30	MMSI number
Reserved for regional or local applications	8	Reserved for definition by a competent regional or local authority. Should be set to zero, if not used for any regional or local application. Regional applications should not use zero.
SOG	10	Speed over ground in 1/10 knot steps (0-102.2 knots) 1 023 = not available, 1 022 = 102.2 knots or higher
Position accuracy	1	1 = high (< 10 m; Differential Mode of e.g. DGNSS receiver) 0 = low (> 10 m; Autonomous Mode of e.g. GNSS receiver or of other Electronic Position Fixing Device) ; default = 0
Longitude	28	Longitude in 1/10 000 min ( $\pm 180$ degrees, East = positive (as per 2's complement), West = negative (as per 2's complement). 181 degrees (6791AC0 hex) = not available = default)
Latitude	27	Latitude in 1/10 000 min ( $\pm 90$ degrees, North = positive (as per 2's complement), South = negative (as per 2's complement), 91 degrees (3412140 hex) = not available = default)
COG	12	Course over ground in 1/10° (0-3599). 3600 (E10 hex)= not available = default; 3601 - 4095 should not be used
True Heading	9	Degrees (0-359) (511 indicates not available = default).
Time stamp	6	UTC second when the report was generated by the EPFS (0-59, or 60 if time stamp is not available, which should also be the default value, or 62 if Electronic Position Fixing System operates in estimated (dead reckoning) mode, or 61 if positioning system is in manual input mode or 63 if the positioning system is inoperative)
Reserved for regional applications	4	Reserved for definition by a competent regional authority. Should be set to zero, if not used for any regional application. Regional applications should not use zero.
spare	<u>4</u> <sub>3</sub>	Not used, should be set to zero.
Assigned Mode Flag	<u>1</u>	<u>0 = Station operating in autonomous and continuous mode = default</u> <u>1 = Station operating in assigned mode</u>
RAIM-Flag	1	RAIM (Receiver Autonomous Integrity Monitoring) flag of Electronic Position Fixing Device; 0 = RAIM not in use = default; 1 = RAIM in use)
Communication State Selector Flag	1	0 = SOTDMA Communication State follows; 1 = ITDMA Communication State follows.

Communication State	19	SOTDMA Communication State (refer to § 3.3.7.2.2), if Communication State Selector Flag is set to 0, or ITDMA Communication State (refer to § 3.3.7.2.3), if Communication State Selector Flag is set to 1.
Total number of bits	168	Occupies one slot

2.56.2 Rationale for Clarification:

- 1.) There was a misinterpretation possible to wrongly interpret the MSB as a North/South or East/West-Flag.
- 2.) An assign mode flag was needed to indicate that the station has entered assigned mode.

2.56.3 Date of amendment: 10.2001

2.56.4 Comment:

No comment

**2.57 A2; § 3.3.8.2.15 Message 19: Extended Class B Equipment Position Report**

2.57.1 Proposed Clarifying Text

*This message should be used by Class B Shipborne Mobile Equipment. This message should be transmitted once every 6 minutes in two slots allocated by the use of Message 18 in the ITDMA Communication State. This message should be transmitted immediately after the following parameter values change: Dimension of Ship/Reference for Position or Type of Electronic Position Fixing Device.*

TABLE 32

Parameter	Number of bits	Description
Message ID	6	Identifier for message 19; always 19
Repeat Indicator	2	Used by the repeater to indicate how many times a message has been repeated. Refer to § 4.6.1; 0 – 3; default = 0; 3 = do not repeat any more.
User ID	30	MMSI number
Reserved for regional or local applications	8	Reserved for definition by a competent regional or local authority. Should be set to zero, if not used for any regional or local application. Regional applications should not use zero.
SOG	10	Speed over ground in 1/10 knot steps (0-102.2 knots) 1 023 = not available, 1 022 = 102.2 knots or higher
Position accuracy	1	1 = high (< 10 m; Differential Mode of e.g. DGNS receiver) 0 = low (> 10 m; Autonomous Mode of e.g. GNSS receiver or of other Electronic Position Fixing Device) ; default = 0
Longitude	28	Longitude in 1/10 000 min ( $\pm 180$ degrees, East = positive (as per 2's complement), West = negative (as per 2's complement). 181 degrees (6791AC0 hex) = not available = default)
Latitude	27	Latitude in 1/10 000 min ( $\pm 90$ degrees, North = positive (as per 2's complement), South = negative (as per 2's complement). 91 degrees (3412140 hex) = not available = default)
COG	12	Course over ground in 1/10 ° (0-3599). 3600 (E10 hex) = not available =

		<i>default; 3 601 - 4 095 should not be used</i>
<i>True Heading</i>	<i>9</i>	<i>Degrees (0-359) (511 indicates not available = default).</i>
<i>Time stamp</i>	<i>6</i>	<i>UTC second when the report was generated by the EPFS (0-59, or 60 if time stamp is not available, which should also be the default value, or 62 if Electronic Position Fixing System operates in estimated (dead reckoning) mode, or 61 if positioning system is in manual input mode or 63 if the positioning system is inoperative)</i>
<i>Reserved for regional applications</i>	<i>4</i>	<i>Reserved for definition by a competent regional authority. Should be set to zero, if not used for any regional application. Regional applications should not use zero.</i>
<i>Name</i>	<i>120</i>	<i>Maximum 20 characters 6 bit ASCII, "@@@@@@@@@@@@@@@@@@@@@@" = not available = default.</i>
<i>Type of ship and cargo type</i>	<i>8</i>	<i>0 = not available or no ship = default; 1 - 99 = as defined in § 3.3.8.2.3.2; 100 - 199 = preserved, for regional use; 200 - 255 = preserved, for future use.</i>
<i>Dimension of Ship/Reference for Position</i>	<i>30</i>	<i>Dimensions of Ship in metres and Reference point for reported position (see Fig. 18 and § 3.3.8.2.3.3)</i>
<i>Type of Electronic Position Fixing Device</i>	<i>4</i>	<i>0 = Undefined (default); 1 = GPS, 2 = GLONASS, 3 = Combined GPS/GLONASS, 4 = Loran-C, 5 = Chayka, 6 = Integrated Navigation System, 7 = surveyed; 8 - 15 = not used;</i>
<i>RAIM-Flag</i>	<i>1</i>	<i>RAIM (Receiver Autonomous Integrity Monitoring) flag of Electronic Position Fixing Device; 0 = RAIM not in use = default; 1 = RAIM in use)</i>
<i>DTE</i>	<i>1</i>	<i>Data terminal ready (0 = available 1 = not available = default) (refer to § 3.3.8.2.3.1)</i>
<u><i>Assigned Mode Flag</i></u>	<u><i>1</i></u>	<u><i>0 = Station operating in autonomous and continuous mode = default</i></u> <u><i>1 = Station operating in assigned mode</i></u>
<i>Spare</i>	<del><i>4</i></del>	<i>Not used. Should be set to zero.</i>
<i>Total number of bits</i>	<i>312</i>	<i>Occupies two slots.</i>

**2.57.2 Rationale for Clarification:**

- 1.) There was a misinterpretation possible to wrongly interpret the MSB as a North/South or East/West-Flag.
- 2.) An assign mode flag was needed to indicate that the station has entered assigned mode

2.57.3 Date of amendment: 10.2001

2.57.4 Comment:

No comment

**2.58 A2; §3.3.8.2.16 Message 20: Data Link Management Message**

**2.58.1 Proposed Clarifying Text**

*This message should be used by base station(s) to pre-announce the fixed allocation schedule (FATDMA) for one or more base station(s) and it should be repeated as often as required. This way the system can provide a high level of integrity for base station(s). This is especially important in regions where several base stations are located adjacent to each other and mobile station(s)*

move between these different regions. These reserved slots cannot be autonomously allocated by mobile stations.

The mobile station should then reserve the slots for transmission by the base station(s) until time-out occurs. The base station should refresh the time-out value with each transmission of Message 20 in order to allow mobile stations to terminate their reservation for the use of the slots by the base stations (refer to § 3.3.1.2).

The parameters "Offset Number", "Number of Slots", "Time-out", and "Increment" should be treated as a unit, meaning that if one parameter is defined all other parameters should be defined within that unit. The parameter "Offset Number" should denote the offset from the slot in which Message 20 was received to the first slot to be reserved. The parameter "Number of Slots" should denote the number of consecutive slots to be reserved starting with the first reserved slot. This defines a reservation block. This reservation block should not exceed 5 slots. The parameter "Increment" should denote the number of slots between the starting slot of each reservation block. If "Increment" is set to zero, there should be no additional reservation blocks. The values recommended for "Increment" are as follows: 2, 3, 5, 6, 9, 10, 15, 18, 25, 30, 45, 50, 75, 90, 125, 150, 225, 250, 375, 450, 750, or 1125. Use of one of these values guarantees symmetric slot reservations throughout each frame. This message applies only to the frequency channel in which it is transmitted.

If interrogated and no data link management information is available, only Offset number 1, number of slot offsets 1, time-out 1, and increment 1 should be sent. These fields should all be set to zero.

TABLE 33

Parameter	Number of bits	Description
Message ID	6	Identifier for message 20; always 20
Repeat Indicator	2	Used by the repeater to indicate how many times a message has been repeated. Refer to § 4.6.1; 0 - 3; default = 0; 3 = do not repeat any more.
Source station ID	30	MMSI number of base station
Spare	2	Not used. Should be set to zero
Offset number 1	12	Reserved offset number; 0 = not available.
Number of slots 1	4	Number of reserved consecutive slots: 1 - 15; 0 = not available
Time-out 1	3	Time-out value in minutes; 0 = not available.
Increment 1	11	Increment to repeat reservation block 1; 0 = not available.
Offset number 2	12	Reserved offset number (Optional)
Number of slots 2	4	Number of reserved consecutive slots: 1 - 15; optional
Time-out 2	3	Time-out value in minutes (optional)
Increment 2	11	Increment to repeat reservation block 2 (optional)

<i>Offset number 3</i>	<i>12</i>	<i>Reserved offset number (optional)</i>
<i>Number of slots 3</i>	<i>4</i>	<i>Number of reserved consecutive slots: 1 - 15; optional</i>
<i>Time-out 3</i>	<i>3</i>	<i>Time-out value in minutes (optional)</i>
<i>Increment 3</i>	<i>11</i>	<i>Increment to repeat reservation block 3 (optional)</i>
<i>Offset number 4</i>	<i>12</i>	<i>Reserved offset number (optional)</i>
<i>Number of slots 4</i>	<i>4</i>	<i>Number of reserved consecutive slots: 1 - 15; optional</i>
<i>Time-out 4</i>	<i>3</i>	<i>Time-out value in minutes (optional)</i>
<i>Increment 4</i>	<i>11</i>	<i>Increment to repeat reservation block 4 (optional)</i>
<i>Spare</i>	<i>max 6</i>	<i>Not used. Should be set to zero The number of spare bits which may be 0, 2, 4, or 6 should be adjusted in order to observe byte boundaries.</i>
<i>Total number of bits</i>	<i>72 – 160</i>	

**2.58.2 Rationale for Clarification:**

Since the SI of a mobile station that sends with a reporting rate of 60 reports/minute is seven (7), this change will ensure that at least 2 available slots will be found. This clarification puts the onus on the configuration of the base station.

2.58.3 Date of amendment: Edition 1.0: 10.2001; Edition 1.3: 09.2002

2.58.4 Comment:

No comment

**2.59 A2; § 3.3.8.2.17 Message 21: Aids to Navigation Report**

**2.59.1 Proposed Clarifying Text**

*This message should be used by an A-to-N AIS station. This station may be mounted on an Aid-to-Navigation or this message may be transmitted by a fixed station when the functionality of an A-to-N station is integrated into the fixed station. This message should be transmitted autonomously at a Reporting Rate of once every three (3) minutes or it may be assigned by an Assigned Mode Command (Message 16) via the VHF data link, or by an external command. This message should not occupy more than two slots.*

TABLE 34

<i>Parameter</i>	<i>Number of bits</i>	<i>Description</i>
<i>Message ID</i>	<i>6</i>	<i>Identifier for this message 21</i>
<i>Repeat Indicator</i>	<i>2</i>	<i>Used by the repeater to indicate how many times a message has been repeated. Refer to § 4.6.1; 0 - 3; default = 0; 3 = do not repeat any more.</i>
<i>ID</i>	<i>30</i>	<i>MMSI number of <u>transmitting station (3)</u></i>
<i>Type of Aids-to-Navigation</i>	<i>5</i>	<i>0 = not available = default; <del>1 – 15 – Fixed Aid to Navigation; 16 – 31 – Floating Aid to Navigation;</del> refer to appropriate definition set up by IALA; refer to Table 34bis.</i>
<i>Name of Aids-to-</i>	<i>120</i>	<i>Maximum 20 characters 6 bit ASCII,</i>



	<u>30, 36, ... 84</u>	<u>Navigation" at the end of that parameter, when more than 20 characters are needed for the Name of the Aid-to-Navigation. This parameter should be omitted when no more than 20 characters for the name of the A-to-N are needed in total. Only the required number of characters should be transmitted, i. e. no @-character should be used.</u>
<u>Spare</u>	<u>0, 2, 4, or 6</u>	<u>Spare. Used only when parameter "Name of Aid-to-Navigation Extension" is used. Should be set to zero. The number of spare bits should be adjusted in order to observe byte boundaries.</u>
<u>Number of bits</u>	<u>272 – 360</u>	<u>Occupies two slots.</u>

Footnotes:

(1) When using 3.3.8.2.3.3 for Aids-to-Navigation the following should be observed:

- For fixed Aids-to-Navigation, virtual A-to-Ns, and for off-shore structures, the orientation established by the dimension A should point to true north.
- For floating aids larger than 2 m \* 2 m the dimensions of the Aids to Navigation should always be given approximated to a ~~circle~~ square, i.e. the dimensions should always be as follows A=B=C=D 0 (This is due to the fact, that the orientation of the floating Aid to Navigation is not transmitted. The reference point for reported position is in the center of the square.)
- A=B=C=D=1 should indicate objects (fixed or floating) smaller than or equal to 2m \* 2m. (The reference point for reported position is in the center of the ~~circle~~ square.)
- For fixed off shore structures that are not fixed, such as rigs, should be considered as Code 31 type from table 34 AtoNs from ITU-R M.1371-1. These structures shall have their "Dimension/reference for position" parameter as determined above in note (1).  
For fixed off shore structures, Code 3 type from table 34, shall have their "Dimension/reference for position" parameter as determined above in note (1). Hence, all off shore AtoNs and structures have the dimension determined in the same manner and the actual dimensions are contained in message 21.

(2) When transmitting virtual~~pseudo~~ Aids to Navigation information, i.e. the virtual/pseudo Aids to Navigation Target Flag is set to one (1), the dimensions should be set to A=B=C=D=0 (default). This should also be the case, when transmitting "reference point" information (see Table 34bis).

*This message should be transmitted immediately after any parameter value was changed.*

*Note on Aids-to-Navigation within AIS:*

*The competent international body for Aids-to-Navigation, IALA, defines an Aid-to-Navigation as: "a device or system external to vessels designed and operated to enhance safe and efficient navigation of vessels and/or vessel traffic." (IALA Navguide, Edition 1997, Chapter 7).*

*The IALA Navguide stipulates: "A floating aid to navigation, which is out of position, adrift or during the night is unlighted, may itself become a danger to navigation. When a floating aid is out of position or malfunctioning, navigational warnings must be given." Therefore, a station, which transmits Message ~~23~~ 21, could also transmit Safety Related Broadcast Message*

*(Message 14) upon detecting that the floating Aid-to-Navigation has gone out of position or is malfunctioning, at the competent authority's discretion.*

(3) When generating synthetic or virtual AtoN targets the MMSI should be the transmitting station's MMSI. In order to discriminate between the individual synthetic or virtual AtoN targets, the name field should be used as an unique alpha-numeric identifier. The receiving application should be able to assemble synthetic or virtual AtoN targets' identities by combining the MMSI and the name field. For Real AtoN targets only the MMSI should be sufficient.

Table 34bis Type of A to N

The nature and type of AtoN can be indicated with 32 different codes, as shown below

	<u>Code</u>	<u>Definition</u>
	<u>0</u>	<u>Default, Type of A to N not specified</u>
	<u>1</u>	<u>Reference point</u>
	<u>2</u>	<u>RACON</u>
	<u>3</u>	<u>Structure off shore, such as oil platforms, wind farms, <del>rigs</del>. (Note: This code should identify an obstruction that is fitted with an Aid-to-Navigation AIS station.)</u>
	<u>4</u>	<u>Spare</u>
<u>Fixed A to N</u>	<u>5</u>	<u>Light, without sectors</u>
	<u>6</u>	<u>Light, with sectors</u>
	<u>7</u>	<u>Leading Light Front</u>
	<u>8</u>	<u>Leading Light Rear</u>
	<u>9</u>	<u>Beacon, Cardinal N</u>
	<u>10</u>	<u>Beacon, Cardinal E</u>
	<u>11</u>	<u>Beacon, Cardinal S</u>
	<u>12</u>	<u>Beacon, Cardinal W</u>
	<u>13</u>	<u>Beacon, Port hand</u>
	<u>14</u>	<u>Beacon, Starboard hand</u>
	<u>15</u>	<u>Beacon, Preferred Channel port hand</u>
	<u>16</u>	<u>Beacon, Preferred Channel starboard hand</u>
	<u>17</u>	<u>Beacon, Isolated danger</u>
	<u>18</u>	<u>Beacon, Safe water</u>
	<u>19</u>	<u>Beacon, Special mark</u>
<u>Floating A to N</u>	<u>20</u>	<u>Cardinal Mark N</u>
	<u>21</u>	<u>Cardinal Mark E</u>
	<u>22</u>	<u>Cardinal Mark S</u>
	<u>23</u>	<u>Cardinal Mark W</u>
	<u>24</u>	<u>Port hand Mark</u>
	<u>25</u>	<u>Starboard hand Mark</u>
	<u>26</u>	<u>Preferred Channel Port hand</u>
	<u>27</u>	<u>Preferred Channel Starboard hand</u>
	<u>28</u>	<u>Isolated danger</u>
	<u>29</u>	<u>Safe Water</u>
	<u>30</u>	<u>Special Mark</u>
	<u>31</u>	<u>Light Vessel / LANBY/Rigs</u>

**Note:**

(1) The types of Aids to Navigation listed above are based on the IALA Maritime Buoyage System, where applicable.

(2) There is potential for confusion when deciding whether an aid is lighted or unlighted. Competent authorities may wish to use the regional/local section of the message to indicate this.

## 2.59.2 Rationale for Clarification:

1.) Rationale for introduction of parameter "Name of A-to-N Extension": IALA recognized that there are many cases, where longer designations for A-to-Ns are required (for details refer to the IALA AIS Guidelines). For a two-slot message, the maximum number of additional characters is 14. The rationale for not allowing more than 2 slots is to optimise the load of the VDL.

2.) Rationale for introduction of parameter "Virtual A-to-N flag": In some situations it might be useful to transmit information on a physically non-existing AtoN. A method is required to differentiate between this type of virtual AtoN targets from real AtoN objects. It is proposed that one of the spare bits in Message #21 be used as a "virtual AtoN flag".

3.) Rationale for introduction of the Type of AtoN table: Recommendation ITU-R M.1371-1 requires so.

4.) Rationale for the introduction of the Assigned mode flag: Since the A-to-N AIS Station may be assigned a different reporting rate, the entering into assigned mode needs to be indicated.

2.59.3 Date of amendment: Edition 1.0: 10.2001; Edition 1.3: 09.2002; Edition 1.4: 09.2003

## 2.59.4 Comment

This message does not affect any other mobile or base station message or AIS VDL behaviour. In particular, this message is output transparently on the Presentation Interface by Class A shipborne mobile stations. This message does, however, affect applications making use of it, both on the transmitting as on the receiving side. Therefore, future amendments should be done in a way to avoid creating legacy problems for applications.

## 2.60 A2; § 4.1.1 Operating frequency channels

### 2.60.1 Proposed Clarifying Text

*Two frequency channels have been designated in RR Appendix S18 for AIS use worldwide, on the high seas and in all other areas, unless other frequencies are designated on a regional basis for AIS purposes. The two designated frequencies are:*

*AIS 1 (Channel 87B, 161.975 MHz), (2087) \*; and*

*AIS 2 (Channel 88B, 162.025 MHz) (2088)\*.*

*The AIS should default to operation on these channels.*

*Operation on other channels should be accomplished by the following means: Manual input commands (manual switching) from AIS input device, TDMA commands from a base station (automatic switching by TDMA telecommand), DSC commands from a base station (automatic switching by DSC telecommand) or commands from shipborne systems, e.g. ECDIS or ENC (automatic switching by shipborne system command) via IEC 61162 command. The last eight (8) received regional operating settings including the region itself should be stored by the mobile station. All stored regional operating settings should be time/date-tagged and they should be tagged with information by what input means this regional operating setting was received*

---

\* See Recommendation ITU-R M.1084, Annex 4.

(TDMA Msg 20, DSC telecommand, Manual input, input via Presentation Interface).

*For channel management when position information is lost during normal operation, the current frequency channel use should be maintained until ordered to change by an addressed channel management message (addressed DSC command or addressed Message 22) or by manual input.*

#### 2.60.2 Rationale for Clarification:

This clarification introduces a time/date and source tag to every memory of regional operating settings. The time/date tag allows the mobile station to determine what regional operating setting should be erased based upon age (refer to clarification of A2, §4.1.8). The source tag allows priorities to be assigned to different sources of channel management setting inputs (refer to clarification of A2, §4.1.8).

2.60.3 Date of amendment: Edition 1.0: 10.2001; Edition 1.3: 09.2002

#### 2.60.4 Comment:

This clarification has been incorporated in the design and tests of Class A shipborne mobile AIS stations as far as mobile stations are affected. Any future change to this clarification should consider not to create a legacy issue.

## 2.61 A2; §4.1.2 Normal default mode of dual channel operation

### 2.61.1 Proposed Clarifying Text

*The normal default mode of operation should be a two-channel operating mode, where the AIS simultaneously receives on both channels in parallel. In order to accomplish this performance, the AIS transponder should contain two TDMA receivers.*

*Channel access is performed independently on each of the two parallel channels.*

*For periodic repeated messages, including the initial link access, the transmissions should alternate between AIS 1 and AIS 2. This alternating behaviour is on a transmission by transmission basis, without respect to time frames.*

*Transmissions of own station following slot allocation announcements of own station, responses of own station to interrogations, responses of own station to requests, and acknowledgements of own station should be transmitted on the same channel as the initial message received.*

*For addressed messages, transmissions should utilize the channel in which messages from the addressed station were last received.*

*For non-periodic messages other than those referenced above, the transmissions of each message, regardless of message type, should alternate between AIS 1 and AIS 2.*

*Base stations could alternate their transmissions between AIS 1 and AIS 2 for the following reasons:*

- To increase link capacity.*
- To balance channel loading between AIS 1 and AIS 2.*
- To mitigate the harmful effects of RF interference.*

*When a base station is included in a channel management scenario, it should transmit addressed messages on the channel in which it last received a message from the addressed station.*

2.61.2 Rationale for Clarification:

Avoid ambiguity with regard to what station is doing what (receiving / sending station)

2.61.3 Date of amendment: 10.2001

2.61.4 Comment:

No comment

**2.62 A2; § 4.1.5 Transitional mode operations near regional boundaries**

2.62.1 Proposed Clarifying Text

*The AIS device should automatically switch to the two-channel transitional operating mode when it is located within five nautical miles, or the transition zone size (see Table 35), of a regional boundary. In this mode the AIS device should transmit and receive on the primary AIS frequency specified for the occupied region; it should also transmit and receive on the primary AIS frequency of the nearest adjacent region. Only one transmitter is required. Additionally, for dual channel operations as specified in § 4.1.2, except when the reporting rate has been assigned by Message 16, when operating in this mode, the reporting rate should be doubled and shared between the two channels (alternate transmission mode). When the AIS is entering the transitional mode, it should continue to utilize the current channels for transmitting for a full one-minute frame while switching one of the receivers to the new channel. The TDMA access rules should be applied to vacating slots on the current channel and accessing slots on the new channel. This transitional behaviour is necessary only when the channels are changing. Regional boundaries should be established by the competent authority in such a way that this two-channel transitional operating mode can be implemented as simply and safely as possible. For example, care should be taken to avoid having more than three adjacent regions at any regional boundary intersection. In this context the high seas area should be considered to be a region where default operating settings apply. The mobile AIS station should ignore any channel management command, when there are three different regional operating settings with adjacent regional operating areas, their corners within eight miles to each other. Regions should be as large as possible. For practical purposes, in order to provide safe transitions between regions, these should be no smaller than 20 nautical miles but not larger than 200 nautical miles on any boundary side. Examples of acceptable and unacceptable regional boundary definitions are illustrated in Figures 19a and 19b.*

FIGURE 19a

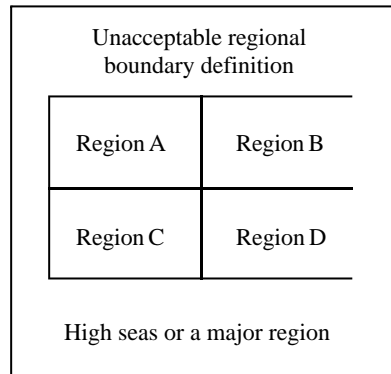
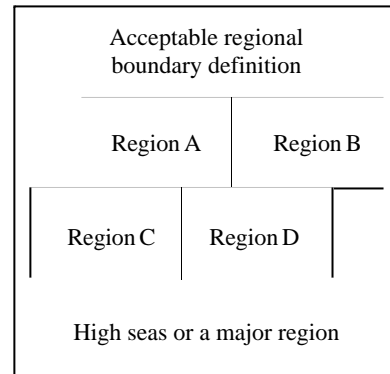

FIGURE 19b



1371-19ab

#### 2.62.2 Rationale for Clarification:

The corner condition for regional operating areas can be easily checked by the mobile station when receiving an channel management input. While the areas defined by the competent authority and transmitted by base stations could be assumed to be correct (the onus is on the competent authority), the mobile station may also be set by the manual input or by the shipborne system. To avoid wrong regional areas from those sources, the clarification was needed. The eight miles are derived from the maximum size of the transition zone.

2.62.3 Date of amendment: 10.2001

2.62.4 Comment:

This clarification has been incorporated in the design and tests of Class A shipborne mobile AIS stations as far as mobile stations are affected. Any future change to this clarification should consider not to create a legacy issue.

### 2.63 A2; § 4.1.5.1 Changing Channel Bandwidth

2.63.1 Proposed Clarifying Text

A competent authority should not assign different bandwidths to adjacent regions that use the same frequency or frequencies. To do this an additional buffer region is required. If a buffer region is not used, the assignments would result in an unstable condition with regard to received messages, incorrectly interpreting slots as being free.

2.63.2 Rationale for Clarification:

Important navigation safety and automatic VDL management information is lost if the AIS is operated under this condition. Nowhere in ITU-R M.1371-1 is there a warning concerning this channel management possibility.

2.63.3 Date of amendment: Edition 1.4: 09.2003

2.63.4 Comment:

The bandwidth dependent parameters of the transmitted signal are defined in A2; §2.1.3. The signal broadcast in 25 kHz. operation is not the same as the signal broadcast in 12.5 kHz. operation. The GMSK demodulator design (See A2; §2.4.1.3.)

is specified differently to match either the 25 kHz. or the 12.5 kHz. signal. The GMSK demodulator is not required to receive both types of transmitted signal using a single design. If the GMSK demodulator fails to correctly decode a received data packet, the corresponding slot is marked as FREE. This incorrect marking can result in the simultaneous use of slots by units that are nearby but set to different bandwidths. This condition degrades the safe operation of the VDL. Authorities should take measures to avoid creating this condition using channel management.

## **2.64 A2; § 4.1.6 Channel management by manual input**

### **2.64.1 Proposed Clarifying Text**

*Channel management by manual input should include the geographical area along with the designated AIS channel(s) for use in that area (refer to Message 22). Manual input should be subject to override by TDMA command, DSC command or shipborne system command, i. e. via Presentation Interface, in accordance with rules laid out in 4.1.8.*

When the user requires a manual input of a regional operating setting, the regional operating settings in use, which may be the default operating settings, should be presented to the user. The user should then be allowed to edit these settings partly or in full. The mobile station should ensure, that a regional operating area is always input and that it conforms to the rules for regional operating areas (refer to 4.1.5). After completion of input of an acceptable regional operating settings set, the AIS should require the user to confirm a second time that the input data should be stored and possibly used instantaneously.

### **2.64.2 Rationale for Clarification:**

- 1.) Shipborne system commands can only be input by the Presentation Interface (if available; in Class A shipborne mobile equipment a Presentation Interface is required).
- 2.) In order to avoid incomplete or invalid manual input to the channel management settings of the mobile station, the user will be prompted with the current regional operating settings, which he may then edit. The mobile station then checks the input for a minimum of consistency and requires the user to confirm the input. Only then the manual may be accepted as regional operating settings. This is to prevent the sensitive channel management setup from lightly undertaken changes while allowing manual input, when need should be there locally.

### **2.64.3 Date of amendment: 10.2001**

### **2.64.4 Comment:**

This clarification has been incorporated in the design and tests of Class A shipborne mobile AIS stations as far as mobile stations are affected. Any future change to this clarification should consider not to create a legacy issue.

## **2.65 A2; § 4.1.8 Priority of channel management commands**

### **2.65.1 Proposed Clarifying Text**

**§ 4.1.8 Priority of channel management commands and clearing of stored regional operating settings**

*The most current and applicable commands received should override previous channel management commands in accordance with the following rules:*

The mobile AIS station should constantly check, if the nearest boundary of the regional operating area of any stored regional operating setting is more than 500 miles away from the current position of own station, or if any stored regional operating setting was older than five weeks. Any stored regional operating setting which fulfils any one of these conditions should be erased from the memory.

The regional operating settings set should be handled as a whole, i. e. a change requested for any parameter of the regional operating settings should be interpreted as a new regional operating setting.

The mobile AIS station should not accept, i. e. ignore, any new regional operating setting which includes a regional operating area, which does not conform to the rules for regional operating areas laid out in 4.1.5.

The mobile AIS station should not accept a new regional operating setting, which was input to it from shipborne system command, i. e. via the Presentation Interface, if the regional operating area of this new regional operating setting partly or totally overlaps or matches the regional operating area of any of the stored regional operating settings, which were received from a base station either by msg 22 or by DSC telecommand within the last two hours.

A message 22 addressed to own station or a DSC telecommand addressed to own station should be accepted only if the mobile AIS station is in a region defined by one of the stored regional operating settings. In this case the set of regional operating settings should be composed by combining the received parameters with the regional operating area in use.

If the regional operating area of the new, accepted regional operating setting overlaps in part or in total or matches the regional operating areas of one or more older regional operating settings, this or these older regional operating settings should be erased from the memory. The regional operating area of the new, accepted regional operating setting may be neighbouring tightly and may thus have the same boundaries as older regional operating settings. This should not lead to the erasure of the older regional operating settings.

Subsequently the mobile AIS station should store a new, accepted regional operating setting in one free memory location of the eight memories for regional operating settings. If there is no free memory location, the oldest regional operating setting should be replaced by the new, accepted one.

No means other than defined herein should be allowed to clear any or all of the stored regional operating settings. In particular, it should not be possible to solely clear any or all of the stored regional operating settings by a manual input or by an input via the Presentation Interface without inputting a new regional operating setting.

#### 2.65.2 Rationale for Clarification:

A clarification was needed as to what exactly are the rules, to use the "most current and most applicable" regional operating settings when there are 8 memory locations to choose from and when there is a possibility that these memory locations at least in part have overlapping or matching regional operating areas. In addition, a precise and globally uniform algorithm was needed to determine how the memory will be managed due to age of entry and source of entry, geographical overlap etc.

2.65.3 Date of amendment: 10.2001

#### 2.65.4 Comment:

This clarification has been incorporated in the design and tests of Class A shipborne mobile AIS stations as far as mobile stations are affected. Any future change to this clarification should consider not to create a legacy issue.

### **2.66 4.3.1.2 Changing Course (applicable to Class A shipborne mobile equipment, only)**

#### 2.66.1 Proposed Clarifying Text

*When a ship changes course, a higher update rate should be required according to Annex 1 Table 1A. Reporting Rate (Rr) should be affected by changing course as described in this paragraph.*

*A change of course should be determined by calculating the mean value of the heading information (HDG) for the last 30 seconds and comparing the result with the present heading. When HDG is unavailable, the Rr should not be affected.*

*If the difference exceeds 5°, a higher Rr should be applied in accordance with Annex 1 - Table 1A. The higher Rr should be maintained by using ITDMA to complement SOTDMA scheduled transmissions in order to derive the desired Rr. When 5° is exceeded, the Reporting Rate should be increased beginning with a broadcast within the next 150 slots (See §3.3.4.2.1) using either a scheduled SOTDMA slot, or RATDMA access slot (See §3.3.5.5).*

*The increased Reporting Rate should be maintained until the difference between the mean value of heading and present heading has been less than 5° for more than 20 seconds.*

#### 2.66.2 Rationale for Clarification:

1. When changing course, this improves the timeliness of manoeuvring information and reduces the dependency on dead reckoned position predictions.
2. As a result, it improves surveillance accuracy from other ships or a Vessel Traffic Service.

2.66.3 Date of amendment: Edition 1.4: 09.2003

#### 2.66.4 Comment:

Current IEC 61993-2 tested equipment does not possess this feature. However, this recommendation may be implemented by a manufacturer without affecting Class A conformance to IEC 61993-2.

## **2.67 A2; § 4.3.2 Assigned Reporting Rates**

### 2.67.1 Proposed Clarifying Text

*A competent authority may assign a Reporting Rate to any mobile station by transmitting Assignment Message 16 from a base-~~or repeater~~ station. . Except for the Class A shipborne mobile AIS station, ~~an assigned reporting rate should have precedence over all other reasons for changing reporting rate.~~ If the autonomous mode requires a higher reporting rate than that directed by Message 16, the Class A shipborne mobile AIS station should use the autonomous mode.*

### 2.67.2 Rationale for Clarification

1.) Separation of functionality of Base Station and Repeater. If a combined Base/Repeater Station is transmitting Msg. 16 then it is due to the Base Station functionality

2.) Consequential clarification to A1; § 4.2.1 Reporting Rate and A2; § 3.3.6 Assigned operation

2.67.3 Date of amendment: 10.2001

2.67.4 Comment:

This clarification has been incorporated in the design and tests of Class A shipborne mobile AIS stations as far as mobile stations are affected. Any future change to this clarification should consider not to create a legacy issue.

## **2.68 A2; §4.4.1 Intentional Slot Reuse by the own station**

### 2.68.1 Proposed Clarifying Text

*A station should reuse time slots only in accordance with this paragraph and only when own position is available.*

*When selecting new slots for transmission, the station should select from its candidate slot set (refer to § 3.3.1.2) within the desired selection interval.*

*When the candidate slot set has less than 4 slots, the station should intentionally reuse available slots, ~~used by other shipborne stations only,~~ in order to make the candidate slot set equal to 4 slots. Slots may not be intentionally reused from stations that indicate no position available. This may result in fewer than 4 candidate slots. The intentionally reused slots should be taken from the most distant station(s) within the selection interval. Slots allocated or used by base stations should not be used unless the base station is located over 120 nautical miles from the own station. When a distant station has been subject to intentional slot reuse, that station should be excluded from further intentional slot reuse during a time period equal to one frame.*

Slot reuse provides candidate slots for random selection. This process attempts to increase the candidate slot set to a maximum of four. When the candidate slot set has reached four, the candidate slot selection process is complete. If four slots have not been identified after all the rules have been applied, this process may report less than four slots. Candidate slots for reuse should be selected using the following priorities beginning with Rule 1 (Also see the slot selection rules Flow Diagram – Figure 21).

Add to the Free slot set (if any) all slots that are:

- Rule 1: FREE (see §3.1.6) on selection channel and AVAILABLE<sup>(1)</sup> (see §3.1.6) on the other channel
- Rule 2: AVAILABLE<sup>(1)</sup> on selection channel and FREE on the other channel
- Rule 3: AVAILABLE<sup>(1)</sup> on both channels.
- Rule 4: FREE on selection channel and UNAVAILABLE<sup>(2)</sup> on the other channel
- Rule 5: AVAILABLE<sup>(1)</sup> on selection channel and UNAVAILABLE<sup>(2)</sup> on the other channel.

- (1) Available – Mobile Station (SOTDMA or ITDMA), or Base Station reserved slot (FATDMA or Message 4) beyond 120 nautical miles.
- (2) Unavailable – Base Station reserved slot (FATDMA or Message 4) within 120 nautical miles, or a Mobile Station reporting without position information.

~~The intentional slot reuse should be performed as indicated in Figure 20 below, which is an example applying these rules, using an example status of slot use on both operating frequency channels:~~

FIGURE 20

		Selection Interval (SI)													
		←	1	2	3	4	5	6	7	8	9	10	11	12	→
Channel A			F	F	F	F	T	T	D	<del>DF</del>	<del>FX</del>	<del>FX</del>	X	B	
Channel B			F	T	D	E	F	T	F	<del>IB</del>	<del>XF</del>	<del>OI</del>	<del>XF</del>	<del>XF</del>	

*It is intended to intentionally reuse one slot within the Selection Interval of frequency channel A. The current status of the use of the slots within the Selection Interval on both frequency channels A and B is given as follows: The slot for intentional slot reuse should then be selected by the following priority (indicated by the number of the slot combination as given in the figure above):*

*Highest Selection Priority: No. 1*

*No. 2*

~~*No. 3*~~

*No. 5*

*No. 6*

*No. 3*

~~*No. 7*~~

*No. 4*

*No. 7*

*Lowest Selection Priority No. 8*

*Combinations 4, 9, 10, 11 and 12 should not be used.*

*Rationale for not using slot combinations:*

~~*No. 4 Allocated by another near station*~~

*No. 9 Adjacent slot rule*

*No. 10 Opposite channel rule*

*No. 11 Adjacent slot rule*

*No. 12 Base station rule*

*F = Free*

*I = Internally allocated (allocated by own station, not in use)*

*E = Externally allocated (allocated by another station near own station)*

*B = Allocated by a base station within 120 nautical miles of own station*

*T = Another station under way that has not been received for 3 minutes or more*

*D = Allocated by the most distant station(s)*

~~*O = Internally allocated (allocated by own station, in use presently)*~~

*X = Should not be used*

Figure 21 (new)  
[Slot selection rules flow diagram]

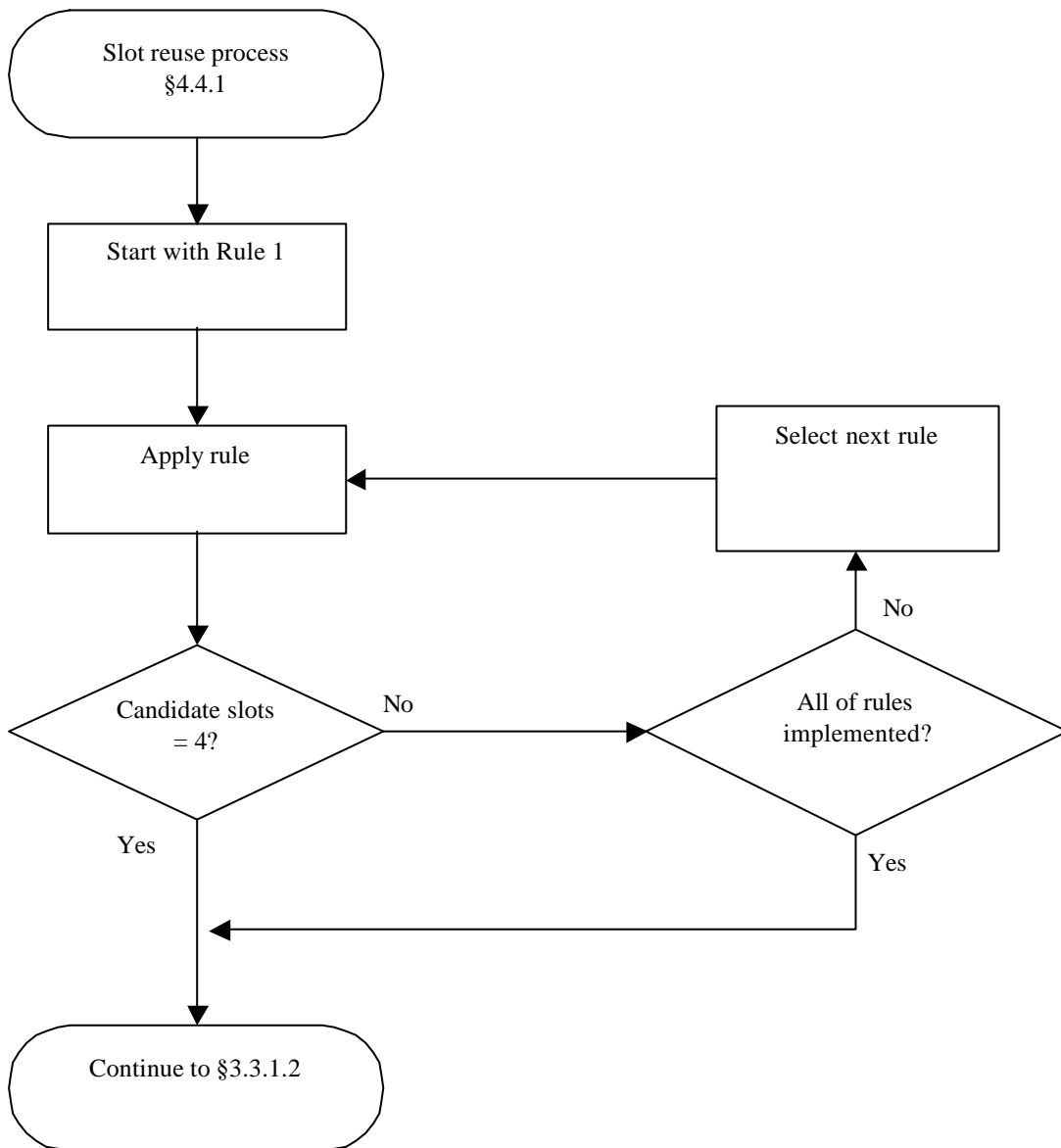

#### 2.68.2 Rationale for Clarification:

- Legend: delete I, replace O by I: There is no slot state "Internally allocated by own station, not in use". Internal allocated slots can be used for transmission.
- Slot combination 4: There is no absolute differentiation between distant station and near station. Intentionally reused slots should be taken from the most distant stations first.
- Slot combination 8: FATDMA reservation applies only to the frequency channel in which it is transmitted (refer 3.3.8.2.16). That causes more flexibility of the system.

Note: While transmitting, the mobile station can not receive a transmission of a Base station on the other channel.

1. The slot reuse rule definitions and their selection priorities are established.
2. The order of the example's results were corrected to properly align with the use of the rules.
3. Wording adjustments were made to reference the rules.
4. A new Figure was added to define how the rules should be applied to the slot selection process.

2.68.3 Date of amendment: 10.2001; Edition 1.4: 09.2003

2.68.4 Comment:

This clarification has been incorporated in the design and tests of Class A shipborne mobile AIS stations. Any future change to this clarification should consider not to create a legacy issue.

The rules describe the relative priorities that should be used when slots are selected. For example, slots, that are EXTERNALLY ALLOCATED and no report has been received for the last three minutes, automatically revert to the FREE slot state. In Figure 20, these are the slots marked with a "T". As FREE slots, the rules require that these slots be selected for reuse before slots that are known to be occupied – designated with a "D" in Figure 20. For this reason, slot number 3 moved down to the fifth "priority position" in the example.

The designations of "D" and "E" shown in the example go back to the original version of ITU-R M.1371 when a definition of "far" and "near" was given (a distance of 12 miles was used as the distinction). This definition was removed when ITU-R M.1371-1 was adopted. These two designations should now be treated as equal. Recognizing this and applying the rules, slot number 4 moves ahead of slot 7 to the sixth "priority position" in the example.

The process of developing these rules uncovered the fact that the Figure 20 example given in ITU-R M.1371-1 is outdated and in need of revision. During the next revision of ITU-R M.1371, consideration should be given to removing the example entirely.

## **2.69 A2; § 4.4.2 Use of Assignment for Congestion Resolution**

### **2.69.1 Proposed Clarifying Text**

*A base station may assign Reporting Rates to ~~shipborne~~ all mobile stations except Class A shipborne mobile AIS stations to resolve congestion and can thus protect the viability of the VDL. To resolve congestion for Class A shipborne mobile AIS stations, the base station may use slot assignments to redirect slots used by the Class A shipborne mobile AIS station to FATDMA reserved slots.*

### **2.69.2 Rationale for Clarification:**

For Class A shipborne mobile AIS stations it is not possible to assign a lower Report Rate than defined in Table 1A.

2.69.3 Date of amendment: 10.2001

2.69.4 Comment:

This clarification has been incorporated in the design and tests of Class A shipborne mobile AIS stations. Any future change to this clarification should consider not to create a legacy issue.

## **2.70 A2; § 4.5 Base Station Operation**

2.70.1 Proposed Clarifying Text

*A base station accomplishes the following tasks, ~~additional to a mobile station~~:*

- 1) *provides synchronization for stations not directly synchronized: ~~Emit~~ Transmits Base Station Reports (Message 4) with the default update rate;*
- 2) *provides transmission slot assignments (refer to § 3.3.6.2 and to § 4.4.2);*
- 3) *provides assignment of Reporting Rates to mobile station(s) (refer to § 3.3.6.1. and to § 4.3.1.4);*
- 4) *~~use of~~ transmits Channel Management Messages;*
- 5) *optionally provides GNSS corrections via the VDL by Message 17 ~~optionally~~.*

2.70.2 Rationale for Clarification:

False statement: Base station functions are not additional to the functions of a mobile station.

2.70.3 Date of amendment: Edition 1.0: 10.2001; Edition 1.3: 09.2002

2.70.4 Comment:

No comment

## **2.71 A2; § 4.6 Repeater Operation**

2.71.1 Proposed Clarifying Text

*AIS base stations should consider repeater operations where it is necessary to provide extended environments ~~for shipborne AIS transponders~~. The extended AIS environment may contain one or more repeaters.*

*In order to implement this function efficiently and safely, the ~~relevant~~ competent authority should perform a comprehensive analysis of the required coverage area and user traffic load, applying the relevant engineering standards and requirements.*

*A repeater may operate in the following modes:*

- 1) *Duplex repeater mode.*
- 2) *Simplex repeater mode.*

2.71.2 Rationale for Clarification:

Functional separation between base- and repeater station.

Extended AIS environment could be provided by repeater operation not just for shipborne mobile AIS stations but for all other mobile and base station messages.

2.71.3 Date of amendment: 10.2001

2.71.4 Comment:

No comment

## **2.72 A2; § 4.6.1.2 Base station/repeater station use of Repeat Indicator**

2.72.1 Proposed Clarifying Text

### ***4.6.1.2 Base station/simplex repeater station use of Repeat Indicator***

The Repeat Indicator should be transmitted by base/repeater stations whenever the transmitted message is a repeat of a message already transmitted from another station.

2.72.2 Rationale for Clarification:

The repeat indicator has no bearing on duplex repeater.

2.72.3 Date of amendment: 10.2001

2.72.4 Comment:

No comment

## **2.73 A2; § 4.6.3.3 Synchronisation and Slot selection**

2.73.1 Proposed Clarifying Text

~~*When another station is synchronizing on a repeater station (base station), only positional information of the specific repeater station should be used. Positional information, included in any repeated message, should be disregarded for this purpose.*~~

*Intentional slot reuse (referred to in § 4.4.1) should be performed when required. In order to assist in slot selection, measurement of received signal strength by the repeater station should be considered. The received signal strength indicator (RSSI) will indicate when two or more stations are transmitting in the same slot at approximately the same distance from the repeater station. A high level of received signal strength will indicate that the transmitting stations are close to the repeater, and a low level of received signal strength will indicate that the transmitting stations are farther away. Congestion resolution on the VDL may be applied (refer to § 4.4.2).*

2.73.2 Rationale for Clarification:

A repeater station does not transmit its own positional information.

2.73.3 Date of amendment: Edition 1.0: 10.2001; Edition 1.3: 09.2002

2.73.4 Comment:

## **2.74 A2; §5.2.1 Conversion to transmission packets**

2.74.1 Proposed Clarifying Text

*The transport layer should convert data, received from the Presentation Interface, into transmission packets. If the length of the data requires a transmission that exceeds five (5) slots (refer to Table 36 for guidance) or, for a mobile AIS station, if the total number of RATDMA transmissions of messages 6, 8, 12, and 14 in this frame exceeds 20 slots the AIS should not transmit the data, and it should respond with a negative acknowledgement to the Presentation Interface.*

*Table 36 is based on the assumption that the theoretical maximum of stuffing bits will be needed. A mechanism may be applied, which determines, prior to transmission, what the actually required bit stuffing will be with reference to § 3.2.2.1, depending on the actual content of the input for transmission from the Presentation Interface. If this mechanism determines that less stuffing bits than indicated in Table 36 would be needed, more data bits than indicated in Table 36 may be transmitted, applying the actually required number of stuffing bits. However, the total number of slots required for this transmission should not be increased by this optimization.*

*Taking into account that safety related and binary messages should be used, it is of importance that the variable messages are set on byte boundaries. In order to ensure that the required bit stuffing for the variable length messages is provided for in the worst case condition, with reference to the packet format (ref. § 3.2.2.2) the following parameters should be used as a guideline:*

Table 36

<i>Number of slots</i>	<i>Maximum Data Bits</i>	<i>Stuffing Bits</i>	<i>Total Buffer Bits</i>
<i>1</i>	<i>136</i>	<i>36</i>	<i>56</i>
<i>2</i>	<i>360</i>	<i>68</i>	<i>88</i>
<i>3</i>	<i>584</i>	<i>100</i>	<i>120</i>
<i>4</i>	<i>808</i>	<i>132</i>	<i>152</i>
<i>5</i>	<i>1 032</i>	<i>164</i>	<i>184</i>

2.74.2 Rationale for Clarification:

editorial clarification

2.74.3 Date of amendment: 10.2001

2.74.4 Comment:

This clarification has been incorporated in the design and tests of Class A shipborne mobile AIS stations. Any future change to this clarification should consider not to create a legacy issue.

**2.75 A2; § 5.3.1 Addressed message**

2.75.1 Proposed Clarifying Text:

*Addressed messages should have a destination user ID. The source station should anticipate an acknowledgement message (Message 7 or Message 13). If an acknowledgement is not received the station should retry the transmission. ~~A time out of~~ The station should wait 4 seconds is allowed before attempting retries. When a transmission is retried, the Retransmit Flag should be set to "retransmitted". The number of retries should be 3, but it ~~should~~ could be configurable between 0 and 3 retries by an external application via the Presentation Interface. When set to a different value by an external application, the number of retries should default to 3 retries after 8 minutes. The overall result of the data transfer should be forwarded to above layers. The acknowledgement should be between transport layers in two stations.*

*Each data transfer packet on the Presentation Interface should have a unique packet identifier consisting of the message type (binary or safety related messages), the source-ID, the destination-ID, and a sequence number.*

*The sequence number should be assigned in the appropriate Presentation Interface message which is input to the station.*

*The destination station should return the same sequence number in its acknowledgement message on the Presentation Interface.*

*The source station should not reuse a sequence number until it has been acknowledged or time-out has occurred.*

*The acknowledgement should be put first in the data transfer queue both on the Presentation Interface and on the VDL.*

*These acknowledgements are applicable only to the VHF data link. Other means must be employed for acknowledging applications.*

*Refer to the following Figure and Annex 6.*

FIGURE 21

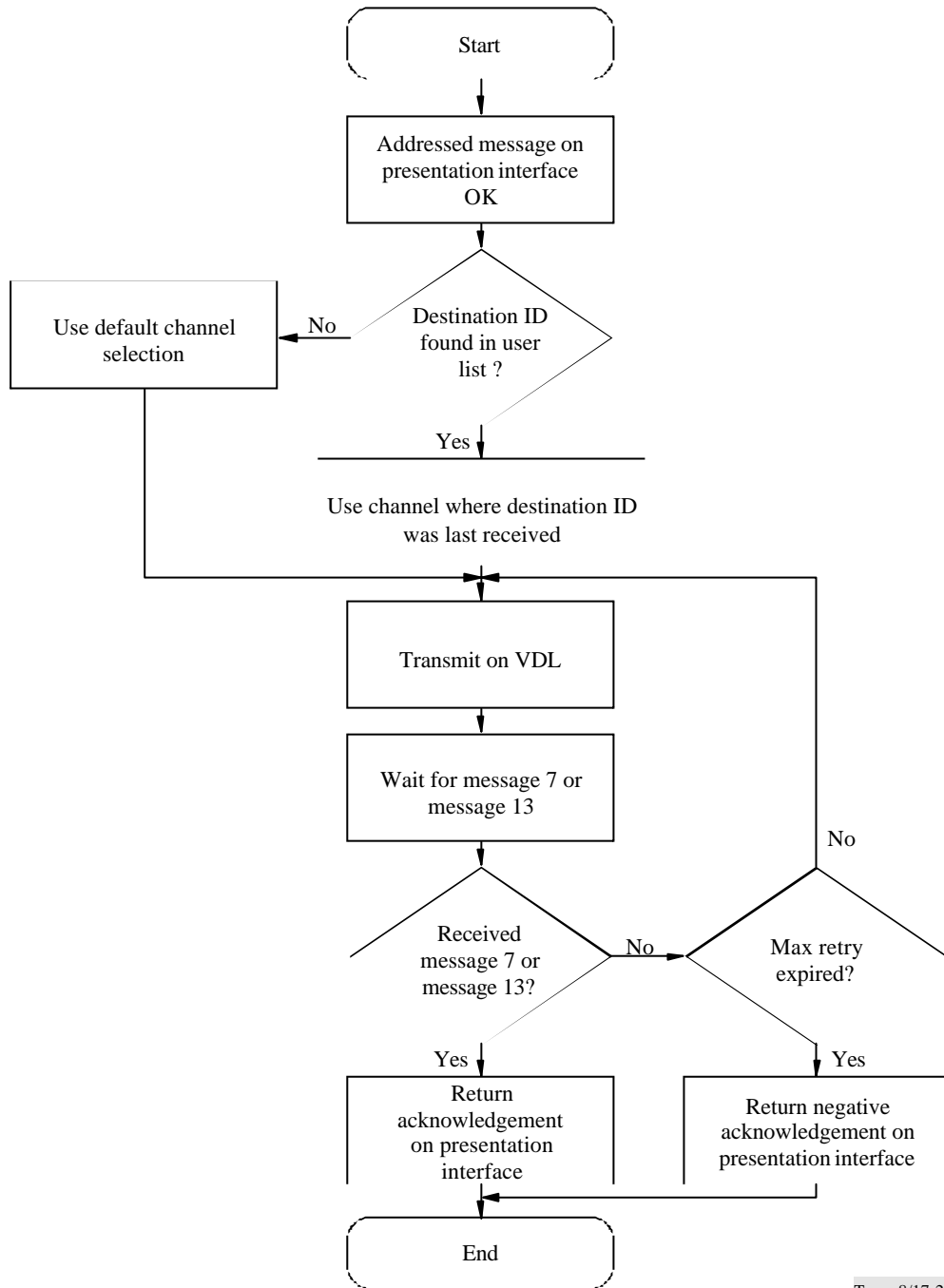

Temp 8/17-21  
(122534)

**2.75.2 Rationale for Clarification:**

(1) Editorial clarification; the word "allow" could be mistakenly interpreted as "allowance", i. e. there could possibly be other settings. There cannot be a randomly selected number of seconds.

(2) "Should" was replaced by "could" because there is no provision for mobiles to be configured via the PI.

2.75.3 Date of amendment: Edition 1.0: 10.2001; Edition 1.3: 09.2002

2.75.4 Comment:

No comment

## 2.76 A3; § 1 General

### 2.76.1 Proposed Clarifying Text

1.1 *The Class A AIS should be capable of performing limited AIS-related DSC operations conforming to the provisions of Recommendations ITU-R M.493, ITU-R M.541 and ITU-R M.825-3. These operations should not include either Annex 2 of Recommendation ITU-R M.825-3 or distress-related features of Recommendation ITU-R M.493. An AIS station should not respond or take action on any calls with categories other than 103. In order to accomplish this performance, the AIS device should contain a dedicated DSC receiver that is tuned permanently to channel 70. However, a dedicated DSC transmitter is not required.*

1.2 The Class B AIS equipment does not transmit DSC, and a DSC receiver is optional.

~~1.23~~ *DSC-equipped shore stations may transmit ~~DSC all-ships~~ VTS area geographic coordinates calls only or calls specifically addressed to individual stations on channel 70 to specify regional boundaries and regional frequency channels and transmitter power level to be used by the AIS in those specified regions. The AIS device should be capable of responding to Expansion Symbols No. 00, 01, 09, 10, 11, 12, and 13 of Table 5 of Recommendation ITU-R M.825-3 by performing operations in accordance with Annex 2, § 4.1 with the regional frequencies and regional boundaries specified by these calls. Calls addressed to individual stations that do not contain Expansion Symbols No. 12 and 13 should be used to command these stations to use the specified channels until further commands are transmitted to these stations. Primary and secondary regional channels (Recommendation ITU-R M.825-3, Table 5) correspond to Table 35 (Message 22) channel A and channel B, respectively. The only value used by Expansion Symbol No 01 should be 2 and 12, meaning 2 watt or 12,5 watt. This applies to TDMA and DSC transmissions. Expansion Symbol No 00 does not affect TDMA channels.*

1.3 *The shore station should ensure that the total DSC traffic should be limited to 0.075 Erlang in accordance with Recommendation ITU-R M.822.*

### 2.76.2 Rationale for Clarification:

1) The AIS mobile station should only operate with Category Symbol No 103 "safety call related to VTS operation" in order not to disturb operation of GMDSS equipment.

2) Refer to ITU Document 8B/TEMP/109-E, 6 May 2002

~~2~~ 3) The AIS mobile station should only operate with 2 watt or 12,5 watt. All other values should be ignored.

~~3~~ 4) Clarifying the use of Expansion Symbol 00, which does affect the DSC VHF working channel only.

2.76.3 Date of amendment: Edition 1.0: 10.2001; Edition 1.2: 02.2002; Edition 1.3: 09.2002

### 2.76.4 Comment

## 2.77 A3; § 2 Scheduling

### 2.77.1 Proposed Clarifying Text

*Shore stations that transmit ~~DSC all ships~~ VTS area geographic coordinates calls only to designate AIS regions and frequency channels should schedule their transmissions such that ships transiting these regions will receive sufficient notice to be able to perform the operations in Annex 2, §§ 4.1.1 to 4.1.5. A transmission interval of 15 minutes is recommended, and each transmission should be made twice, with a time separation of 500 ms between the two transmissions, in order to ensure that reception by AIS transponders is accomplished.*

*2.1 DSC operations performed by the AIS should be scheduled subject to the TDMA operations such that ~~the~~ either TDMA TX or RX operations are not impaired or delayed, i.e. DSC calls from mobiles should be transmitted only when there is a sufficient, consecutive number of free TDMA slots available for the time period equivalent to the duration of the intended DSC call.*

*2.2 The automatic response to DSC calls addressed to a "VTS area" should be transmitted after a random delay, distributed over the range of 0 to 20 s, providing the DSC signaling channel is clear of other traffic and subject to the restrictions of § 2.1.*

### 2.77.2 Rationale for Clarification:

- 1) Refer to ITU Document 8B/TEMP/109-E, 6 May 2002
- 2) Clarification of DSC operations in AIS.

2.77.3 Date of amendment: Edition 1.2: 02.2002; Edition 1.3: 09.2002

### 2.77.4 Comment

## 2.78 A3; § 3 Polling

### 2.78.1 Proposed Clarifying Text

*3.1 The Class A [see rational 3] AIS should be capable of automatically transmitting a DSC response to an interrogation request for information, as specified in Recommendation ITU-R M.825-3, Annex 1. An automatic response should be transmitted to any interrogation containing one or more of the symbols 101, ~~102~~ 102, 103, 104, 108, 109, 111, 112 and 116 of Table 4 of Annex 1 of Recommendation ITU-R M.825-3. When an automatic response is required, but the requested information is not available, the relevant symbol in the response should be followed by the symbol 126. If own station Type of Ship and Cargo Type parameter of Message 5 is other than 50-99 (refer to Annex 2, § 3.3.8.2.3.2), then the type of ship response to a DSC poll (Table 3 of ITU-R M.825-3) should be 99.*

### 2.78.2 Rationale for Clarification:

- 1.) ~~Symbol 102 is "Report your position now and at intervals of ... minutes". This assignment function was in DSC does not apply for AIS.~~ Symbol 102 does apply for AIS.
- 2.) The Type of Ship and Cargo Type parameter of Message 5 was further developed although originally identical to the Table 3 of M.825. Therefore, a clarification is needed about how the AIS should respond on the DSC channel to a type-of-ship-qualified DSC poll, when a different type of ship is set than encoded by 50 – 99.
- 3.) The Class B AIS equipment can not transmit DSC.

2.78.3 Date of amendment: Edition 1.0: 10.2001; Edition 1.1: 12.2001; Edition 1.4: 09.2003

2.78.4 Comment:

This clarification has been incorporated in the design and tests of Class A shipborne mobile AIS stations. Any future change to this clarification should consider not to create a legacy issue.

## **2.79 A3; § 4 Regional channel designation**

2.79.1 Proposed Clarifying Text

*4.1 For designation of regional AIS frequency channels, expansion symbols No. 09, 10 and 11 should be used in accordance with Table 5 of Recommendation ITU-R M.825-3. Each of these expansion symbols should be followed by two DSC symbols (4 digits) which specify the AIS regional channel(s), as defined by Recommendation ITU-R M.1084, Annex 4. This allows for simplex, duplex, 25 kHz and 12.5 kHz channels for regional options, subject to the provisions of Appendix S18 of the Radio Regulations. Expansion symbol No. 09 should designate the primary regional channel, and expansion symbol No. 10 or 11 should be used to designate the secondary regional channel. The RF interference environment flag does not apply to AIS. It should be set to zero.*

Designation of regional channels should also consider Annex 2, § 4.1.5.1 and § 4.1.9.

*4.2 When single-channel operation is required, expansion symbol No. 09 should be used, only. For two-channel operation, either expansion symbol No. 10 should be used to indicate that the secondary channel is to operate in both transmit and receive modes, or expansion symbol No. 11 should be used to indicate that the secondary channel is to operate only in receive mode.*

2.79.2 Rationale for Clarification:

Clarifying the use of Expansion Symbol No 09, No 10 and No 11.

DSC channel management should follow the same rules as TDMA channel management.

2.79.3 Date of amendment: Edition 1.2: 02.2002; Edition 1.4: 09.2003

2.79.4 Comment:

## **2.80 A3, § 5 Regional area designation**

2.80.1 Proposed Clarifying Text

*For designation of regional areas for utilizing AIS frequency channels, expansion symbols No. 12 and 13 should be in accordance with Table 5 of Recommendation ITU-R M.825-3. Expansion symbol No. 12 should be followed by the geographical coordinate address of the northeastern corner of the Mercator projection rectangle to the nearest tenth of a minute. Expansion symbol No. 13 should be followed by the geographical coordinate address of the southwestern corner of the Mercator projection rectangle to the nearest tenth of a minute. When using DSC for regional area designation it should be assumed that the transitional zone size has the default value (5 nautical miles) For calls addressed to individual stations, expansion symbols No. 12 and 13 may be omitted (see § 1.2 of this Annex).*

**2.80.2 Rationale for Clarification:**

There is no symbol in DSC for transitional zone size. Therefore the default value should be used.

**2.80.3 Date of amendment: 10.2001**

**2.80.4 Comment:**

No comment

**2.81 A5; § 3.1 International Function Message 0: Text telegram using 6-bit ASCII**

**2.81.1 Proposed Clarifying Text**

*This international function message should be used by a ship or base station to send 6-bit ASCII text telegram to other AIS stations. The text telegram can be sent with either binary message 6 or 8. The acknowledge required flag should not be set when using the broadcast message 8*

Table 38

<i>Parameter</i>	<i>Number of bits</i>	<i>Description</i>
<i>Acknowledge required</i>	<i>1</i>	<i>1 = Reply is required 0 = Reply is not required</i>
<i>Message sequence number</i>	<i>11</i>	<i>Sequence number to be incremented by the application</i>
<i>Text message</i>	<del>924</del> <u>908</u>	<i>6-bit ASCII as defined in Annex 2, Table 14. When using this IFM, the number of slots used for transmission should be minimized taking into account the table below.</i>
<i>Spare bits</i>	<i>N</i>	<i>Formula for inserting for spare bits</i>
<i>Total Number of Bits</i>	<del>936</del> <u>920</u>	

*The following table gives the number of 6-bit-ASCII characters, so that the whole message fits into a given number of slots. It is recommended that any application minimizes the use of slots by limiting the number of characters to the numbers given, if possible:*

<i>Number of slots</i>	<i>Maximum number of 6-bit-ASCII characters</i>	
	<i>Addressed Binary Message, 06</i>	<i>Broadcast Binary Message</i>
<i>1</i>	<i>8</i>	<i>14</i>
<i>2</i>	<i>46</i>	<i>51</i>
<i>3</i>	<i>83</i>	<i>88</i>
<i>4</i>	<i>120</i>	<i>126</i>
<i>5</i>	<i>158</i>	<i>163</i>

**2.81.2 Rationale for Clarification**

Correcting wrong number of bits since AI was not incorporated in the previous calculation.

2.81.3 Date of amendment: Edition 1.1: 12.2001

2.81.4 Comment:

## 3 Mapping of sections of M.1371-1 to different kind of AIS stations

### 3.1 General

Different kind of AIS devices can be defined:

a) Mobile stations

- Class A shipborne mobile AIS stations, confirming the IMO carriage requirements,
- Class B shipborne mobile AIS stations, not falling under the IMO carriage requirements,
- SAR airborne mobile AIS stations,
- A-to-N (Aid to navigation) stations, mobile based; in addition, there may be an A-to-N transmission process be added to an AIS base station.

b) Fixed stations

- AIS base stations,
- AIS simplex repeater stations,
- AIS duplex repeater stations.

(Note: "Mobile" and "fixed" is referred to as VDL related functionality. A station, which behaves like a "mobile" station on the VDL, may be fixed, and vice versa.)

**For Class B, SAR and AtoN AIS stations these tables may not reflect the latest developments. An attempt was made however to indicate what would be required in order to fulfil the requirement for 1371-1 compatibility. Areas of uncertainties have been identified by question mark. THESE COLUMNS WILL BE UPDATED WITH THE NEXT EDITION (Ed. 1.4) OF THIS DOCUMENT.** In the future additional new types of AIS devices will appear e.g. Class A derivatives for regional applications (e.g. the European inland waterways) or receive only shipborne mobile AIS devices, etc. These are not included expressively in this document. However, these future types of AIS devices should be designed in accordance with the description given herein which fits best, e.g. regional derivatives of Class A shipborne mobile AIS equipment should comply to the functional requirements of Class A shipborne mobile AIS equipment, or receiving-only shipborne mobile AIS devices should comply with the receiving functionality of Recommendation ITU-R M. 1371-1 which applies to either Class A or Class B shipborne mobile AIS equipment

The following table maps all sections/paragraphs in Recommendation ITU-R M.1371-1 for the types of AIS devices. The table gives an overview of **whether a certain section/paragraph applies** compulsory, recommended or only as an option or whether it should not be used by this particular AIS device at all. Reading of the table is as follows:

There are a number of footnotes and remarks in the table which are explained in the 'Remarks' column.

There are some question marks included, indicating section applications, which have to be discussed further.

When an '@' is given in the paragraph column, also the sub paragraphs are included in that function.

### 3.2 Sections or paragraphs

For each type of device, there are 4 small columns showing the applicability, where 'x' indicates that the section/paragraph is applicable, and '—' that the section/paragraph is not applicable. The meaning of the four applicability columns is:

- C Compulsory in any configuration
- N Not allowed; must not be done or used or output
- R Recommended, but not part of minimum requirements
- O purely optional
- V Transmit if VDM sentence is received

Example:

Annex, Paragraph of M.1371-1	Short description	Cl. A shipborne mobile station				Cl. B shipborne mobile station				SAR aircraft mobile station				Remarks	
		C	N	R	O	C	N	R	O	C	N	R	O		
A2, 3.2.2.11	Long transmission packets	x					x							x	8) Limit to 2 slots.

This section is Compulsory for Cl A, Not allowed for Cl B and Optional for SAR. For Cl B the message is limited to 2 slots.

### 3.3 Section/paragraphs describing Messages

Each message as described in A2, 3.3.8.2.1.....18 can have the following functions:

- G Generate the message and transmit
- R Receive, process and internal use of the message
- P Presentation interface output
- T Transmit by repeater station after receiving it (repeat)

Example:

Annex, Paragraph of M.1371-1	Short description	Cl. A shipborne mobile station				Cl. B shipborne mobile station				Repeater station Simplex				Remarks
		C	N	R	O	C	N	R	O	C	N	R	O	
A2, 3.3.8.2.1	Message 1, 2, 3 Position report	G	T			R	G			R	G		P	

This message will be generated by a Cl A system only, explicitly not by the others, all systems will receive it and send it to the presentation interface (optional for repeater station). Cl A and Cl B may not repeat it but the repeater station will do that.

Summarized:

- x Applicable
- Not Applicable
- ? to be discussed
- @ paragraph description, including sub-paragraphs

- C Compulsory in any configuration
- N Not allowed; must not be done or used or output
- R Recommended, but not part of minimum requirement
- O purely Optional

- G Generate and transmit
- R Receive, process and internal use
- P Presentation interface output
- T Transmit by repeater stations after receiving (repeat).  
This functionality is not allowed for AIS base stations.
- V Transmit if VDM sentence is received



x applicable  
 -- Not Applicable  
 ? to be discussed  
 @ paragraph description, including sub-paragraphs

C Compulsory in any configuration  
 N Not allowed; must not be done or used or output  
 R Recommended, but not part of minimum requirement  
 O purely Optional

G Generate and transmit  
 R Receive, process and internal use  
 P Presentation interface output  
 T Transmit by repeater stations after receiving (repeat)  
 V Transmit if VDM sentence is received

Annex, Paragraph of M.1371-1	Short description	Cl. A shipborne mobile station				Cl. B shipborne mobile station				SAR aircraft mobile station				A-to-N station				Limited base station				Base station				Repeater station Simplex				Repeater station Duplex				Remarks				
		C	N	R	O	C	N	R	O	C	N	R	O	C	N	R	O	C	N	R	O	C	N	R	O	C	N	R	O	C	N	R	O					
A2, 1	Structure	x				x				x				x				x				x				x				x				x				
A2, 2	<b>Physical layer</b>	x				x				x				x				x				x				x				x				x				
A2, 2.1.1 A2, 2.1.2 A2, 2.1.3	Physical layer, Parameters, General, Constants and Bandwith except Table 2 PH.TXP	x				x				x				x				x				x				x				x				x				
A2, 2.1.1	Table 2 PH.TXP High setting of transmit output power	x							x				x				x	x				x				x				x				1) Because high altitude transmitting power need to be considered. The proposal is to switch off the transmitter for high altitude, switch to low transmitting power setting at medium altitude and to normal operation at low altitude.				
	Table 2 PH.TXP Low setting of transmit output power	x				x				x			1)	x				x				x				x				x								
A2, 2.1.4	Transmission media	x			2)	x				x				x				x				x				x				X <sub>2a</sub>				2) For Long Range see remark A4 2a) The AIS duplex repeater should operate on a duplex pair as specified by a competent authority.				
A2, 2.1.5	Dual channel operation, 2 receivers	x				x				x				x				x				x				x								—				
	Transmission on 2 frequencies	x							x	x				x				x				x				x				x								
A2, 2.2	<del>Reverse back to</del> Operates on 25	x				x				x				x				x				x				x				x								



x applicable  
 -- Not Applicable  
 ? to be discussed  
 @ paragraph description, including sub-paragraphs

C Compulsory in any configuration  
 N Not allowed; must not be done or used or output  
 R Recommended, but not part of minimum requirement  
 O purely Optional

G Generate and transmit  
 R Receive, process and internal use  
 P Presentation interface output  
 T Transmit by repeater stations after receiving (repeat)  
 V Transmit if VDM sentence is received

Annex, Paragraph of M.1371-1	Short description	Cl. A shipborne mobile station				Cl. B shipborne mobile station				SAR aircraft mobile station				A-to-N station				Limited base station				Base station				Repeater station Simplex				Repeater station Duplex				Remarks				
		C	N	R	O	C	N	R	O	C	N	R	O	C	N	R	O	C	N	R	O	C	N	R	O	C	N	R	O	C	N	R	O					
																																						5a) An AIS base station with internal DSC functionality should shut down the transmission after 1.1 seconds.
A2, 2.15	Safety precautions	x				x				x				x				x				x				x				x				x				
A2, 3	<b>Link layer</b>	x				x				x				x				x				x				x				x				x				
A2, 3.1	<b>Sublayer 1</b> Medium Access Control (MAC)	x				x				x				x				x				x				x				x				x				
A2, 3.1.1	TDMA synchronization, 1 <sup>st</sup> paragraph	x				x				x				x				x				x				x								x				
	MAC SyncBaseRate		x				x				x				x				x				x				x				x				x			
	MAC SyncMobileRate	x					x 6)				x 6)				x ? 6)				x				x				x				x							
A2, 3.1.1.1	UTC direct	x				x				x				x				x				x				x				x				x				
A2, 3.1.1.2	UTC indirect	x				x				x				x				x				x				x				x				x				
A2, 3.1.1.3	Synchronized to base station	x				x				x				x				x				x				x				x				x				7) although 3.1.1.3 is only applicable for mobile AIS stations, an AIS base or an AIS simplex repeater station should be allowed to synchronise to an(other) AIS base station.
A2, 3.1.1.4	Number of received stations except being able to become semaphore <u>[capable of semaphore synchronisation]</u>	x				x				x				x				x				x				x				x				x				
	<del>Can be a Being able to become</del> semaphore	x					x 6)				x 6)				x ? 6)	x			x				x				x				x							
A2, 3.1.2	Time division	x				x				x				x				x				x				x				x				x				

x applicable  
 -- Not Applicable  
 ? to be discussed  
 @ paragraph description, including sub-paragraphs

C Compulsory in any configuration  
 N Not allowed; must not be done or used or output  
 R Recommended, but not part of minimum requirement  
 O purely Optional

G Generate and transmit  
 R Receive, process and internal use  
 P Presentation interface output  
 T Transmit by repeater stations after receiving (repeat)  
 V Transmit if VDM sentence is received

Annex, Paragraph of M.1371-1	Short description	Cl. A shipborne mobile station				Cl. B shipborne mobile station				SAR aircraft mobile station				A-to-N station				Limited base station				Base station				Repeater station Simplex				Repeater station Duplex				Remarks				
		C	N	R	O	C	N	R	O	C	N	R	O	C	N	R	O	C	N	R	O	C	N	R	O	C	N	R	O	C	N	R	O					
A2, 3.1.3.1	Slot phase synchronization	x				x				x				x				x				x				x				x				x				
A2, 3.1.3.2	Frame synchronization	x				x				x				x				x				x				x				x				x				
A2, 3.1.3.3	Synchronization Transmitting stations	x				x	6)			x	6)			x	?		6)	x				x				x				x				x				
A2, 3.1.3.3.1	Base station operation		x			x				x				x				x				x				x				x				x				
A2, 3.1.3.3.2	Mobile station operation as a semaphore	x				x	6)			x	6)			x	?		6)	x				x				x				x				x				
A2, 3.1.3.4 @ 3.1.3.4.3	Synchronization Receiving stations	x				x				x				x				x				x				x				x				x				
A2, 3.1.4	Slot identification	x				x				x				x				x				x				x				x				x				
A2, 3.1.5	Slot access	x				x				x				x				x				x				x				X <sub>6a</sub>								6a) The transmitter should begin transmission by turning on the RF power at slot start. The transmitter should be turned off after the last bit of the transmission packet has left the transmission unit. HDLC flags may be used to turn off the transmitter.
A2, 3.1.6	Slot state	x				x				x				x				x				x				x				x				x				

x applicable  
 -- Not Applicable  
 ? to be discussed  
 @ paragraph description, including sub-paragraphs

C Compulsory in any configuration  
 N Not allowed; must not be done or used or output  
 R Recommended, but not part of minimum requirement  
 O purely Optional

G Generate and transmit  
 R Receive, process and internal use  
 P Presentation interface output  
 T Transmit by repeater stations after receiving (repeat)  
 V Transmit if VDM sentence is received

Annex, Paragraph of M.1371-1	Short description	Cl. A shipborne mobile station				Cl. B shipborne mobile station				SAR aircraft mobile station				A-to-N station				Limited base station				Base station				Repeater station Simplex				Repeater station Duplex				Remarks				
		C	N	R	O	C	N	R	O	C	N	R	O	C	N	R	O	C	N	R	O	C	N	R	O	C	N	R	O	C	N	R	O					
A2, 3.2 @	<b>Sublayer 2</b> Data link services (DLS) except 3.2.2.11, Long transmission packets	x				x				x				x				x				x				x				x				x				8) 3.2.2.8.2 Distance delay may need consideration with respect to SAR. The proposal is to switch off the transmitter for high altitude, switch to low transmitting power setting at medium altitude and to normal operation at low altitude. See also note 1). 8a) The following subparagraphs are "compulsory" for the AIS duplex repeater, however: 3.2.2, 3.2.2.2, 3.2.2.3, 3.2.2.4 (Start flag should be used to detect a valid received message), 3.2.2.7, 3.3.2.8, 3.2.2.8.3, 3.2.2.9, 3.2.2.10, 3.2.2.11. For A2, §3.2.2.6: <b>not allowed</b> (duplex repeater turn around).
A2, 3.2.2.11	Long transmission packets	x				x							x				x	x				x				x				x				9) Limit to 2 slots?				
A2, 3.3	<b>Sublayer 3</b> Link management entity (LME)	x				x				x				x				x				x				x								--				
A2, 3.3.1 @	Access to data link	x				x				x				x				x				x				x								--				
A2, 3.3.2	Modes of operation	x				x				x				x				x				x								--	--							
A2, 3.3.2.1	<del>Autonomous and</del> continuous	x				x				x				x					x			x								--	--							
	<del>autonomous</del>	x				x				x				x				x				x								--	--							
A2, 3.3.2.2	Assigned	x				x				x				x					x						x <sup>10</sup>					--	--	10) An AIS base station can not be placed in the assigned mode via the VDL using message 16. See also comment 17).						
A2, 3.3.2.3	Polled	x				x				x				x					x			x								--	--							

x applicable  
 -- Not Applicable  
 ? to be discussed  
 @ paragraph description, including sub-paragraphs

C Compulsory in any configuration  
 N Not allowed; must not be done or used or output  
 R Recommended, but not part of minimum requirement  
 O purely Optional

G Generate and transmit  
 R Receive, process and internal use  
 P Presentation interface output  
 T Transmit by repeater stations after receiving (repeat)  
 V Transmit if VDM sentence is received

Annex, Paragraph of M.1371-1	Short description	Cl. A shipborne mobile station				Cl. B shipborne mobile station				SAR aircraft mobile station				A-to-N station				Limited base station				Base station				Repeater station Simplex				Repeater station Duplex				Remarks	
		C	N	R	O	C	N	R	O	C	N	R	O	C	N	R	O	C	N	R	O	C	N	R	O	C	N	R	O	C	N	R	O		
A2, 3.3.3	Initialization	x				x				x				x				x				x				x				x				--	
A2, 3.3.4	Channel access schemes	x				x				x				x				x				x				x				x				--	
A2, 3.3.4.1 @	ITDMA	x				x				x			11)	x			12)	x				x				x				x				--	11) refer to clarification at A2, 3.3.8.2.7, Msg. 9 and Msg. 9 in A2, Table 13 12) ITDMA and FATDMA are only feasible and therefore may be only used if a A-to-N or a Simplex Repeater is combined with a Base Station
A2, 3.3.4.2 @	RATDMA	x				x				x				x				x				x				x				x				--	
A2, 3.3.4.3 @	FATDMA		x				x				x				x		12)		x		13)		x				x				x			--	<u>13) Provide slot designation methods so FATDMA access can be an option.</u>
A2, 3.3.4.4 @	SOTDMA	x				x				x				x				x				x			14)	x				x				--	14) refer to footnote (2) of A2, Table 13. SOTDMA Communication State operation stays as defined in 3.3.7.2.2, except when slot time out is zero (0), then slot Offset equals 2250.
A2, 3.3.5 @	Autonomous and continuous operation using SOTDMA	x				x				x				x			15)	x				x				X 15 a)				x 15 a)				--	15) the autonomous and continuous mode of operation of a A-to-N is achieved using RATDMA. 15a) An AIS base or an AIS simplex repeater station is not operating in the autonomous mode.

x applicable  
 -- Not Applicable  
 ? to be discussed  
 @ paragraph description, including sub-paragraphs

C Compulsory in any configuration  
 N Not allowed; must not be done or used or output  
 R Recommended, but not part of minimum requirement  
 O purely Optional

G Generate and transmit  
 R Receive, process and internal use  
 P Presentation interface output  
 T Transmit by repeater stations after receiving (repeat)  
 V Transmit if VDM sentence is received

Annex, Paragraph of M.1371-1	Short description	Cl. A shipborne mobile station				Cl. B shipborne mobile station				SAR aircraft mobile station				A-to-N station				Limited base station				Base station				Repeater station Simplex				Repeater station Duplex				Remarks	
		C	N	R	O	C	N	R	O	C	N	R	O	C	N	R	O	C	N	R	O	C	N	R	O	C	N	R	O	C	N	R	O		
A2, 3.3.6 @	Assigned operation for mobile stations	x 16)				x 16)				x 16)				x 16)					x				x				x							--	16) description of the reaction of the mobile units reflects only cl A type of message. The others keep the standard message. An assigned mode flag is indicating the use of assigned mode for Class B, AtoN, SAR airborne mobile AIS stations. 17) According to this description, an AIS base station or an AIS repeater station may not be switched into assigned mode because they are not operating in the autonomous mode.
A2, 3.3.7	Message structure	x				x				x				x				x				x				x				x				--	
A2, 3.3.7.1	Message ID	x				x				x				x				x				x				x				x				--	
A2, 3.3.7.2 @	SOTDMA structure	x				x				x				x					x				x				x				x			--	19) refer to "IALA Recommendation on AIS Shore Stations and networking aspects related to the AIS Service", section 26.4
A2, 3.3.7.3 @	ITDMA structure	x				x				x 11)				x 12)					x				x				x				x			--	
A2, 3.3.7.4 @	RATDMA structure	x				x				x				x				x				x				x				x				-- 20)	20) in A2, §3.3.7.4.2 delete the words "§4.6.2 and", Rational: does not apply
A2, 3.3.7.5	FATDMA structure		x				x				x				x				x				x				x				x			-- 21)	21) in A2, §3.3.7.5 delete the words "§4.6.2 and", Rational: does not apply
A2, 3.3.8	Message types	x				x				x				x				x				x				x				x				--	
A2, 3.3.8.1	Message summary	x				x				x				x				x				x				x				x				--	
A2, 3.3.8.2	Message description	x				x				x				x				x				x				x				x				--	

x applicable  
 -- Not Applicable  
 ? to be discussed  
 @ paragraph description, including sub-paragraphs

C Compulsory in any configuration  
 N Not allowed; must not be done or used or output  
 R Recommended, but not part of minimum requirement  
 O purely Optional

G Generate and transmit  
 R Receive, process and internal use  
 P Presentation interface output  
 T Transmit by repeater stations after receiving (repeat)  
 V Transmit if VDM sentence is received

Annex, Paragraph of M.1371-1	Short description	Cl. A shipborne mobile station				Cl. B shipborne mobile station				SAR aircraft mobile station				A-to-N station				Limited base station				Base station				Repeater station Simplex				Repeater station Duplex				Remarks	
		C	N	R	O	C	N	R	O	C	N	R	O	C	N	R	O	C	N	R	O	C	N	R	O	C	N	R	O	C	N	R	O		
A2, 3.3.8.2.1	Message 1, 2, 3 Position report	G R P	T			R G T	P			R G T	P			R G T	P			R V P	G			R G P	V			R T	G			R T	G			P	
A2, 3.3.8.2.2	Message 4 Base station report	R P	G T			R G T	P			R G T	P			R G T	P			R V P	G			G R P	V			R T	G			R T	G			P	22) If repeated by an AIS simplex repeater which is indicated by Repeat Indicator, then the UTC given in these messages may not be accurate due to the repeat delay.
	Message 11 UTC and data response	G R P	T			R T	P	G ?		R T	P	G ?		R T	P	G ?		R V P	G			R P	G V			R T	G			R T	G			P	
A2, 3.3.8.2.3 @	Message 5 Ship static and voyage related data	G R P	T			R G T	P			R G T	P			R G T	P			R V P	G			R P	G			R T	G			R T	G			P	
A2, 3.3.8.2.4 @	Message 6 Addressed binary message	G R P	T			R T	P	G 22 bis)	G 9)	R T	P	G 22 bis)		R T	P	G 22 bis)		G R P	V			G R P	V			R T	G			R T	G			P	<u>22 bis) Presentation Interface output only messages addressed to station MMSI</u>
A2, 3.3.8.2.5	Message 7 Binary acknowledgement Message 13 Safety related acknowledgement	G R P	T			R T	P			R T	P			R T	P			R V P	G			R P	G			R T	G			R T	G			P	
A2, 3.3.8.2.6	Message 8 Binary broadcast message	G R P	T			R T	P	G 9)		R T	P	G 9)		R T	P	G 9)		R V P	G			R P	G			R T	G			R T	G			P	

x applicable  
 -- Not Applicable  
 ? to be discussed  
 @ paragraph description, including sub-paragraphs

C Compulsory in any configuration  
 N Not allowed; must not be done or used or output  
 R Recommended, but not part of minimum requirement  
 O purely Optional

G Generate and transmit  
 R Receive, process and internal use  
 P Presentation interface output  
 T Transmit by repeater stations after receiving (repeat)  
 V Transmit if VDM sentence is received

Annex, Paragraph of M.1371-1	Short description	Cl. A shipborne mobile station				Cl. B shipborne mobile station				SAR aircraft mobile station				A-to-N station				Limited base station				Base station				Repeater station Simplex				Repeater station Duplex				Remarks
		C	N	R	O	C	N	R	O	C	N	R	O	C	N	R	O	C	N	R	O	C	N	R	O	C	N	R	O	C	N	R	O	
A2, 3.3.8.2.7	Message 9 Standard SAR Aircraft Position report	R P	G T			R G P	T			G T P				R G T				R P	G V			R P	G V			R T	G			R T	G			23) How is the static data of a SAR aircraft transmitted? 24) see remark 8): distance delay 3.2.2.8.2
A2, 3.3.8.2.8	Message 10 UTC time and data inquiry	G R P	T			G R	T		P	G R	T		P	G R	T		P	R P	V G			G R P	V			R T	G			R T	G			
A2, 3.3.8.2.9  3.3.8.2.10	Message 12 Addressed safety related message  Message 14 Safety related broadcast message	GR P 22 bis)	T			R T G P 22 bis)				G R P 22 bis)	T			GR P 22 bis)	T			R V				G R P V				R T	G			R T	G			
A2, 3.3.8.2.11	Message 15 Interrogation	G 25) R P	T			R G 25)	T		P	G R 25)	T		P	R T				G 25) P	R bis G P	V		G 25) R P V				R T	G			R T	G			25) refer to A 2, Table in § 3.3.8.2.11 25a) Only repeat if slot offset = 0. <u>25 bis) LBS can not be interrogated</u>
A2, 3.3.8.2.12	Message 16 Assigned mode command	R P	G T			R G T		P	R G T		P	R G T		P	R 26 b) P	V G			GR 26 b) P V				R T 25a 26a	G			R T	G			26) refer to A2, § 3.3.6 26a) Adjust content of message to reflect the new offset value. <u>26 b) LBS and a Base station can not be assignd by msg 16.</u>			
A2, 3.3.8.2.13	Message 17 GNSS broadcast binary message	R P	G T			R 28) G T		P	R G T		P	R G T		P	R P	V G			R P G				R T 27a	G			R T	G			27) if implemented 27a) System design should take into account the maximum delays allowed for repeating DGNSS			

x applicable  
 -- Not Applicable  
 ? to be discussed  
 @ paragraph description, including sub-paragraphs

C Compulsory in any configuration  
 N Not allowed; must not be done or used or output  
 R Recommended, but not part of minimum requirement  
 O purely Optional

G Generate and transmit  
 R Receive, process and internal use  
 P Presentation interface output  
 T Transmit by repeater stations after receiving (repeat)  
 V Transmit if VDM sentence is received

Annex, Paragraph of M.1371-1	Short description	Cl. A shipborne mobile station				Cl. B shipborne mobile station				SAR aircraft mobile station				A-to-N station				Limited base station				Base station				Repeater station Simplex				Repeater station Duplex				Remarks								
		C	N	R	O	C	N	R	O	C	N	R	O	C	N	R	O	C	N	R	O	C	N	R	O	C	N	R	O	C	N	R	O									
																																						correction messages 17. 28) IALA recognizes that IEC is developing and maintaining a test standard for Class B shipborne mobile AIS equipment. When developing this standard, IEC is asked to consider, that all Class B shipborne mobile AIS stations should have the <u>same</u> fallback arrangements and priorities with regard to the use of EPFS (Electronic Position Fixing System) as provided for in IEC's test standard for Class A shipborne mobile equipment. This includes also the same use of Msg. 17 as in Class A shipborne mobile AIS equipment. Additionally, when an internal GNSS is used for position reporting it should comply to the same quality level as defined in the test standard for Class A shipborne mobile equipment with regard to position reporting.				
A2, 3.3.8.2.14	Message 18 Standard Cl B equipment position report	R	G			R	T	G		R	G			R	G			P	R	V		R	G			R	G			R	G			P	R	G		P				
A2, 3.3.8.2.15	Message 19 Extended Cl B equipment position report	R	G			R	T	G		R	G			R	G			P	R	V		R	G			R	G			R	G			P	R	G		P				
A2, 3.3.8.2.16	Message 20 Data link management message	R	G			R	G		P	R	G			P	R	T		P	R	V		G	V			R	T			P	R	G		P				see also 3.3.7.5				

x applicable  
 -- Not Applicable  
 ? to be discussed  
 @ paragraph description, including sub-paragraphs

C Compulsory in any configuration  
 N Not allowed; must not be done or used or output  
 R Recommended, but not part of minimum requirement  
 O purely Optional

G Generate and transmit  
 R Receive, process and internal use  
 P Presentation interface output  
 T Transmit by repeater stations after receiving (repeat)  
 V Transmit if VDM sentence is received

Annex, Paragraph of M.1371-1	Short description	Cl. A shipborne mobile station				Cl. B shipborne mobile station				SAR aircraft mobile station				A-to-N station				Limited base station				Base station				Repeater station Simplex				Repeater station Duplex				Remarks						
		C	N	R	O	C	N	R	O	C	N	R	O	C	N	R	O	C	N	R	O	C	N	R	O	C	N	R	O	C	N	R	O							
A2, 3.3.8.2.17	Message 21 Aids-to-navigation report	R P	G T			R T	G T	P		R T	G T	P		G T	R P			R P	V G			R P	V G			G T				R T	G T	P		R T	G T	P				
A2, 3.3.8.2.18	Message 22 Channel management	R P	G T				G T	R P		R T	G T	P			G T	R P		R P	V G			G R P V								R T	G T	P		R T	G T	P				
A2, 4	<b>Network layer</b>	x				x				x				x				x				x				x				x				--						
A2, 4.1	Dual channel operation except DSC component and manual input (4.1.6)	x				x ?				x ?				x ?				x				x 27a 27b								x 27 a 27 b 27 c					--					27a) for A2, §4.1: Receiving message 22 not applicable for AIS base station and AIS simplex repeater station; for A2, §4.1.1: Compulsory in general but channel selection is done by configuration sentences only. There is no requirement for storing received regional operating settings; for A2, §4.1.3: by configuration; for A2, §4.1.5: An AIS base station or an AIS simplex repeater should only operate in one designated area and should not be subject to move via transition to another area; for A2, §4.17 and §4.1.8: <b>not allowed</b> 27b) for A2, §4.1.4 : <b>Not allowed</b> ; these rules apply for mobile AIS stations only. 27c) A2, §4.1.6, §4.1.7, §4.1.8, §4.1.9 not applicable for AIS simplex repeaters

x applicable  
 -- Not Applicable  
 ? to be discussed  
 @ paragraph description, including sub-paragraphs

C Compulsory in any configuration  
 N Not allowed; must not be done or used or output  
 R Recommended, but not part of minimum requirement  
 O purely Optional

G Generate and transmit  
 R Receive, process and internal use  
 P Presentation interface output  
 T Transmit by repeater stations after receiving (repeat)  
 V Transmit if VDM sentence is received

Annex, Paragraph of M.1371-1	Short description	Cl. A shipborne mobile station				Cl. B shipborne mobile station				SAR aircraft mobile station				A-to-N station				Limited base station				Base station				Repeater station Simplex				Repeater station Duplex				Remarks				
		C	N	R	O	C	N	R	O	C	N	R	O	C	N	R	O	C	N	R	O	C	N	R	O	C	N	R	O	C	N	R	O					
<u>A2.4.1.1</u>	<u>Operating frequency channels</u>	x				<u>x</u> <u>27</u> <u>d)</u>				<u>x</u> <u>2</u>				<u>x</u> <u>2</u>				<u>x</u>				<u>x</u> <u>27</u> <u>e)</u>				<u>x</u>												<u>27d) Channel management by DSC may not be required</u> <u>27e) Compulsory in general but channel selection is done by configuration sentences only. There is no requirement for storing received regional operating settings</u>
<u>A2.4.1.2</u>	<u>Normal default mode of dual channel operation</u>	<u>x</u>				<u>x</u>				<u>x</u>				<u>x</u>				<u>x</u>				<u>x</u>				<u>x</u>												
<u>A2.4.1.3</u>	<u>Regional operation frequencies</u>	<u>x</u>				<u>x</u> <u>27</u> <u>f)</u>				<u>x</u>				<u>x</u>				<u>x</u> <u>27</u> <u>g)</u>				<u>x</u>				<u>x</u>												<u>27f) When not possible does not transmit</u> <u>27g) configuration</u>
<u>A2.4.1.4</u>	<u>Regional operation areas</u>	<u>x</u>				<u>x</u>				<u>x</u>				<u>x</u>				<u>x</u>				<u>x</u>				<u>x</u>				<u>=</u>								<u>These rules apply for mobile stations only</u>
	DSC channel	x							x 3)				x ?				x 3)	x							x	x								DSC channel management is optional for base stations				
<u>A2.4.1.5</u>	<u>Transitional mode operations near regional boundaries</u>	<u>x</u>				<u>x</u>				<u>x</u>				<u>x</u>				<u>x</u>				<u>x</u>				<u>x</u>												<u>A base station should only operate in one designated area and should not subject be to move via transition to another area</u>
<u>A2.4.1.5.1</u>	<u>Conditions for changing bandwidth only</u>	<u>=</u>				<u>=</u>				<u>=</u>				<u>=</u>				<u>=</u>				<u>x</u>				<u>=</u>												

x applicable  
 -- Not Applicable  
 ? to be discussed  
 @ paragraph description, including sub-paragraphs

C Compulsory in any configuration  
 N Not allowed; must not be done or used or output  
 R Recommended, but not part of minimum requirement  
 O purely Optional

G Generate and transmit  
 R Receive, process and internal use  
 P Presentation interface output  
 T Transmit by repeater stations after receiving (repeat)  
 V Transmit if VDM sentence is received

Annex, Paragraph of M.1371-1	Short description	Cl. A shipborne mobile station				Cl. B shipborne mobile station				SAR aircraft mobile station				A-to-N station				Limited base station				Base station				Repeater station Simplex				Repeater station Duplex				Remarks
		C	N	R	O	C	N	R	O	C	N	R	O	C	N	R	O	C	N	R	O	C	N	R	O	C	N	R	O	C	N	R	O	
A2, 4.1.6	Channel management switch by manual input	x				x ?				x ?							x	--				--				--				--				
<u>A2, 4.1.7</u>	<u>Resumption of operation after power on</u>	<u>x</u>				<u>x</u>				<u>x</u>				<u>x</u>					<u>x</u>				<u>x</u>			<u>=</u>				<u>=</u>				
<u>A2, 4.1.8</u>	<u>Priority of channel management commands</u>	<u>x</u>				<u>x</u>				<u>x</u>							<u>?</u>	<u>x</u>					<u>x</u>			<u>=</u>				<u>=</u>				
<u>A2, 4.1.9</u>	<u>Conditions of changing both AIS operational frequency channels</u>		<u>=</u>				<u>=</u>				<u>=</u>				<u>=</u>				<u>x</u>				<u>=</u>			<u>=</u>				<u>=</u>				
A2, 4.2 @	Distribution of transmission packets, except 4.2.2.1 for AtoN position reports (optional)	x				x				x				x				x				x				x 31)				--				31) for A2, §4.2.2 and §4.2.3 not allowed
A2, 4.3	Reporting rates	x				x				x				x				x				x				--				--				
A2, 4.3.1 @	Autonomously changed reporting rate	x 32)				x 32)					x				x				x				x			--				--				32) as applicable
A2, 4.3.2	Assigned reporting rates	x				x				x 33)				x 33)					x				x			--				--				33) only if allowed to be a semaphore
A2, 4.4	Data link congestion resolution	x				x				x				x				x				x				x				--				
A2, 4.4.1	Intentional slot reuse by own station	x				x				x				x				x				x				x				--				
A2, 4.4.2	Use of assignment for congestion resolution	x				x				x				x				x				x				--				--				
A2, 4.5	Base station operation		x				x				x				x				x				x				x			--				base station functions are not <b>additional</b> to mobiles
A2, 4.6	Repeater operation		x				x				x				x				x				x			x				x				repeater station is a different kind of AIS device and not a base station
A2, 4.6.1.1	Repeat indicator (Mobile use)	x				x				x				x				--				--				--				--				

x applicable  
 -- Not Applicable  
 ? to be discussed  
 @ paragraph description, including sub-paragraphs

C Compulsory in any configuration  
 N Not allowed; must not be done or used or output  
 R Recommended, but not part of minimum requirement  
 O purely Optional

G Generate and transmit  
 R Receive, process and internal use  
 P Presentation interface output  
 T Transmit by repeater stations after receiving (repeat)  
 V Transmit if VDM sentence is received

Annex, Paragraph of M.1371-1	Short description	Cl. A shipborne mobile station				Cl. B shipborne mobile station				SAR aircraft mobile station				A-to-N station				Limited base station				Base station				Repeater station Simplex				Repeater station Duplex				Remarks				
		C	N	R	O	C	N	R	O	C	N	R	O	C	N	R	O	C	N	R	O	C	N	R	O	C	N	R	O	C	N	R	O					
A2, 4.6.1.2 @	Repeat indicator (Base/repeater station use)	--				--				--				--								x	x							x				--				33a) An AIS base station does not increase the repeat indicator by repeating via received VDM sentence. An AIS base station should pre-set the repeat indicator to a value between 0 and 3, default=0 for generated messages. For A2, 4.6.1.2.1: <b>not allowed</b> 33b) Simplex repeater station should increment the value of the repeat indicator as described in 4.6.1.2.1
A2, 4.6.2	Duplex repeater mode	--				--				--				--				x				x				x				x								
A2, 4.6.3 @	Simplex repeater mode	--				--				--				--				x				x				x								--				
A2, 4.7	Handling errors related to packets	x				x				x				x				x				x								--				--				
A2, 5	<b>Transport layer</b>	x				x				x				x				x				x								x				x				
A2, 5.1	Transmission packet	x				x				x				x				x				x								x				--				



x applicable  
 -- Not Applicable  
 ? to be discussed  
 @ paragraph description, including sub-paragraphs

C Compulsory in any configuration  
 N Not allowed; must not be done or used or output  
 R Recommended, but not part of minimum requirement  
 O purely Optional

G Generate and transmit  
 R Receive, process and internal use  
 P Presentation interface output  
 T Transmit by repeater stations after receiving (repeat)  
 V Transmit if VDM sentence is received

Annex, Paragraph of M.1371-1	Short description	Cl. A shipborne mobile station				Cl. B shipborne mobile station				SAR aircraft mobile station				A-to-N station				Limited base station				Base station				Repeater station Simplex				Repeater station Duplex				Remarks							
		C	N	R	O	C	N	R	O	C	N	R	O	C	N	R	O	C	N	R	O	C	N	R	O	C	N	R	O	C	N	R	O								
																																						all types of AIS. Proposed is future development by: Cl. B: IEC standard for Cl. B AIS SAR: IALA (with guidance from IMO) AtoN: IALA AIS Committee base station: IALA AIS Committee repeater stations: IALA AIS Committee			
A3 @	<b>DSC</b>	x							x 3)				x 3)				x 3)				x 3)					--				--											
A4 @	<b>Long range</b>	x							x				x				x	x							x					--				--							
A5 @	<b>Application specific messages</b>			--				--				--				--				--				--				--				--		--				Application specific messages are put through transparently.			
A6 @	<b>Sequencing of transmission packets</b>	x				x				x				x				x				x								--				--							